



REDEFINING LASER ACCURACY

# HEAVY DUTY

## Wheel Alignment



# Advanced Alignment Runway Systems

Raise vehicles to the right work height with the versatile Bee Line system

*Bee Line's Advanced Alignment Runway Systems (AA) puts your work at the ideal height to gauge, adjust and correct toe, camber, caster and more. Designed with axle correction in mind, it provides the proper clearance for the unique Bee Line floating beam system and heavy-duty air lift jack. This robust, multi-functional workhorse is available in two work heights – 24 and 30 inch.*



The forward runways are removable for easy access to the vehicle when making adjustments.

## Specifications:

- Tread width: 45" to 100"
- Load capacity: 16 tons per vehicle axle.
- Runway Sections: Removable 19" x 45" (25" x 45" optional)
- Pit Dimensions Available

## ADVANTAGES

### Accommodates any vehicle and fits any floor plan

Bee Line delivers custom solutions in a variety of Drive-on, Drive-thru and Pit model configurations. The add-a-unit design accommodates any vehicle length and fits any floor plan.

### Interchangeable options

Custom design an alignment system to best fit your facilities and production requirements by choosing among many Bee Line alignment components.

### Expandable to meet future needs

The AA Machine safeguards your investment against obsolescence by its flexibility to expand to meet any future needs. If your business relocates, the system can be disassembled and moved to the new location.

# Runway Setups

Custom configurations accommodate any bay

Typical samples of Alignment Runway setups are illustrated below. Bee Line engineers will custom-design any configuration to best fit your shop floor space.

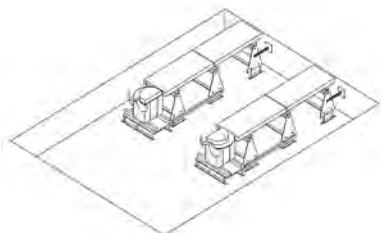

Two Section AA Pit Model with Turning Aligners for Wheel Alignment.

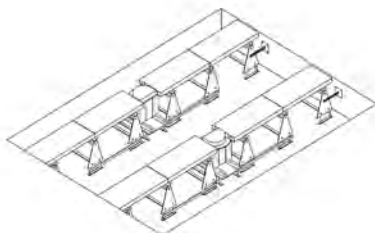

Four Section AA Drive Thru Pit Model with Turning Aligners for Wheel Alignment.

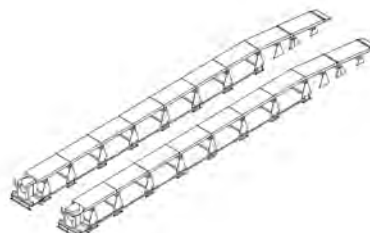

Seven Section AA Above Ground Model with 15'9" Double Approach Ramps and Turning Aligners. 9' Single Approaches are also available for cars and light trucks.

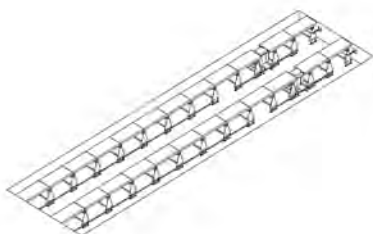

Twelve Section Drive Thru AA Pit Model with Turning Aligners for Wheel and Frame Alignment.

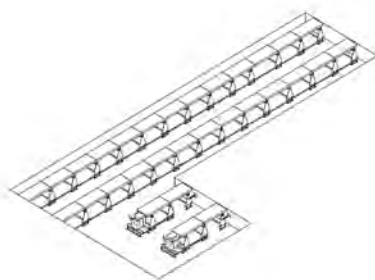

"L" Pit - Thirteen Section Drive Thru Frame Machine and Two-Section AA Pit Model with Turning Aligners for Wheel and Frame Alignment.

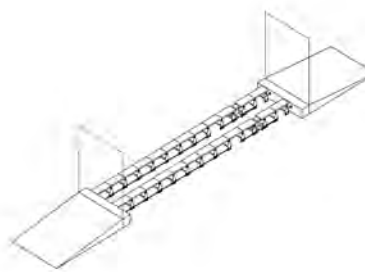

Twelve Section Drive Thru AA Pit Model with Turning Aligners and exterior concrete approaches for Wheel and Frame Alignment.

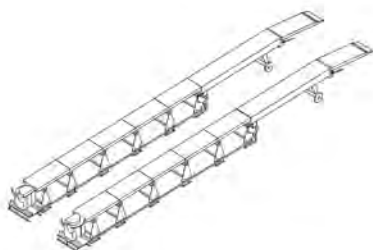

Five Section Above Ground AA with Space Saver Approach Ramps. Include Turning Aligners for Wheel Alignment.

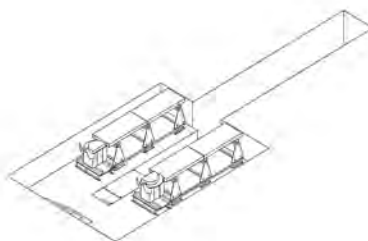

Two Section T-Style Step Down Center Pit with Turning Aligners for Wheel Alignment and easy under truck access.

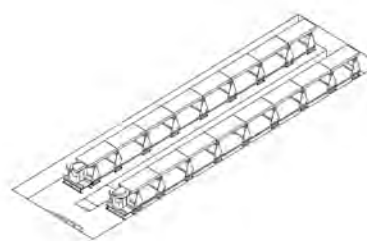

Eight Section Step Down Center Pit with Turning Aligners for Wheel Alignment and easy under truck access.



Typical Two Section T-Style Pit



Space Saver with Step Down Center Pit



Advanced Aligner Runways in Use with Frame Press

# Space Saver Ramp

Designed for the Shop Where Space is at a Premium

*Bee Line designed the Space Saver Ramp to fit in a smaller area than a standard ramp. In the "down" position, the truck is driven up an easy slope, then a major section of the ramp is raised hydraulically to the height of the Advanced Aligner Runways.*



## ADVANTAGES

### Save Valuable Space

The Space Saver lifting ramp raises hydraulically, requires less runway sections and ultimately frees up more floor space in your shop. It can accommodate the longest truck on the market, but spans the shortest possible distance.

### Gradual Incline

The approach ramp incline angle is perfect for low profile buses and RVs. Drive on without bottoming out and easily clear overhead obstructions.

### Specifications:

- Length of Approach Ramp: 23' 4"
- Lifting Length: 16'
- Ramp Height: 24" or 30"
- Lifting Capacity: 11 tons, hydraulically powered
- Newly engineered synchronized lift assures a smooth, even lift side-to-side
- AR401 model is used with 24" high Runway Sections. Incline angle: 4.5 Degrees
- AR401.30 model is used with 30" high Runway Sections. Incline angle: 5.7 Degrees



With the truck in position, Runways are hydraulically lifted with the touch of a button.



The longer design of the Space Saver lifting ramp creates a more gradual incline and requires less runway sections.

# King Pin Turning Aligners

Maximum Accuracy with Incredible Durability

*Bee Line's patented design provides a natural, unrestricted arc that follows the rotation of the king pin motion when rotated or turned. This proven method gives the most consistent, accurate reading of steering geometry possible.*



Twelve Steel roller bearings add durability versus Teflon roller bearings that tend to flatten under load over time.

## ADVANTAGES

### Designed to Handle Heavy Loads

Long-lasting, heavy duty steel roller bearings are positioned under the turntable plates to support large load capacities and set Bee Line apart from the competition. The safety stops can be lowered, but not removed. This helps safeguard against alignment tech oversight.

### Handles All Aspects of Alignment

Bee Line's exclusive KPI Turning Aligners handle all aspects of alignment: toe, camber, caster, KPI (SAI), toe change, load change, max turn angle and all-wheel alignment (four wheels).

Turning Aligners allow the steer tires to turn at a wide 55 degree turning angle and make it easier for the alignment technician to accurately set steering stops.

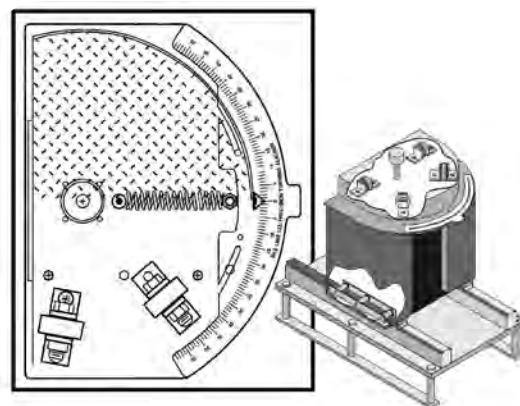

Sturdy construction handles a variety of vehicles. Designed to safely handle 32,000 pounds per axle.

### King Pin Turning Aligner Specifications:

- Axial thrust bearing moves freely to handle side-to-side loads and allow for ease of rotation.
- Available in 24" & 30" heights to match AA work heights.
- Adjustable tread widths: 39" to 94" or 54" to 108"
- Adjustable safety stops

# LC7500 Computer Alignment

Superior Accuracy and Intuitive Design Equals Maximum ROI

*Key innovative refinements come together in the LC7500 to deliver the ultimate return on your investment. The system boasts up to 20% faster processing for added productivity. Users claim an increase of one more alignment per day, generating thousands of dollars more per week in additional revenue – without extending hours or adding more technicians. The LC7500 is the most technologically advanced computer alignment system available today.*



## ADVANTAGES

### The entire system can be calibrated in a few minutes right in your shop

The LC7500 is unique to the industry because it gives the technician the ability to maintain the precision of Bee Line alignment equipment.

Exclusively through Bee Line, there is no downtime and no additional bills from service reps to maintain the accuracy of your alignment system. Your technician can calibrate, as needed, in just a few minutes.

### Intuitive functionality provides unmatched productivity

Windows-based WindSpeed 7500 software makes training simple with integrated help videos and service manuals that are uncomplicated and straightforward. Several videos appear in the help section that guide the user through the specific procedure. If more complex assistance is needed, Bee Line provides remote

help. Our technology experts virtually remote access your machine to speed up diagnosis and quickly offer a solution.

### Smarter technology increases precision and speed

More than 1800 sensors calculate the laser strike to an accuracy of 1/1000th of a degree driving greater customer satisfaction and resulting in fewer comebacks. The Laser Line Generator with 200 sensors per inch provides great precision in these calculations. These technological improvements afford a faster, more precise and extremely accurate alignment, in less time.

*This system allows technicians to easily gauge toe, camber, caster, KPI and steering stops, as well as rear tracking on tractors and trailers when combined with the 22000 Rear Axle Aligner.*

## ALIGNMENT SOFTWARE



**WINDSPEED7500**  
ALIGNMENT SOFTWARE



Interactive alignment heads with live readings are a "workstation" for the technician. Wireless up to 1,000 feet.

# Redefining Laser Accuracy from the Inside Out

## Free Software Updates

- Minimize Downtime**
- Bee Line Windows-based software works with any PC.

- Increased Visibility**
- An impressive 32" HD Monitor is easily visible at a greater distance.

## Superior Design Maximizes Efficiency

- Technician becomes more productive
- Heads stored vertically to minimize risk of damage
- Stable cabinet prevents tipping
- Printer storage drawer built-in

- Built-in Calibration** fixtures and on-board help videos show the technician how to easily calibrate the equipment in the shop.
- No service call required.
  - No additional cost.

## On-Board Assist/ Remote Access

- F1 Help Section
- Training Videos
- Virtual Software Updates
- Minimizes Downtime and Costs

## Improved Durability

- Fewer moving parts in the laser assembly reduces wear, loss of accuracy and the need for repair.

## Accuracy

- More than 1800 sensors calculate the laser strike to an accuracy of 1/1000th of a degree.



## Simultaneous Displays

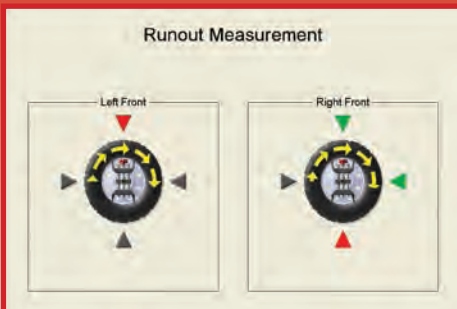

When a step is illustrated on the computer monitor...



...the same step is displayed with live readings on the head.

# Rear/Tandem Axle Alignment

The Bee Line 22000 Rear Axle Aligner puts your trucks on the right track

*Centerline alignment allows the technician to gauge and correct tracking to the angles the truck manufacturer intended. For best tire and fuel performance, rear axles must be perpendicular to the frame, and tires must be perpendicular to the axles. The Bee Line Rear Axle Aligner quickly assists the technician to get those angles right.*

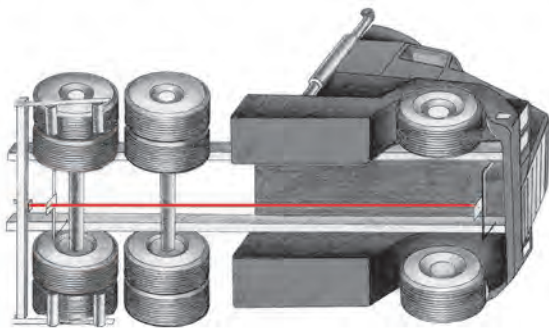

The proven 22000 lets you accurately position your rear axles perpendicular to the vehicle's centerline so the wheels travel in a straight line.



Newly redesigned cradles are just as durable, yet lighter and more easily maneuvered around the tires than ever before. The cradles feature rack and pinion gearing to assure accuracy when determining the axle center.

## ADVANTAGES

### Better performance with Centerline Alignment

Rear axle alignment is the second most critical tire wearing angle. Tracking misalignment can be very costly, reducing gas mileage and causing premature tire wear on front and rear tires.

Using the Bee Line method, all rear axles, including offset axles and axles with different tire spacers or different tire sizes, are set perfectly at 90 degrees to the centerline of the vehicle. Regardless of whether the vehicle is centered over the chassis or not.

A truck that runs straighter, with less drag or resistance due to misaligned rear axles, will assure better tire performance and fuel economy. That's why centerline alignment is the preferred choice of professionals.

### No Run-out. No need to lift the vehicle off the ground.

The Bee Line self-centering wheel cradles assure the correct position of the laser when seated on the cradles in relation to the axle. Wheel cradles eliminate the need for taking run-out and raising the vehicle off the floor, so the operator can gauge the suspension alignment in its operational position.



# Centerline Gauging

## ADVANTAGES

### 22000 Rear Axle Aligner Features:

- Access to AC power is not required.
- Long life ni-cad battery powers the laser for up to 20 hours before recharging.
- Wheel cradles weigh less than 20 lbs. and the rear beam only 10 lbs.
- User-friendly construction allows even novices to set up the Rear Axle Aligner and one person can take all necessary measurements in just a few minutes.
- Calibrates reliably and quickly to assure consistent accuracy with no added expense or service fee.



The aluminum beam is seated parallel to the axle and emits a laser beam that travels through a slot in the rear target hanging in a centered position between the frame rails.

## TRACKING

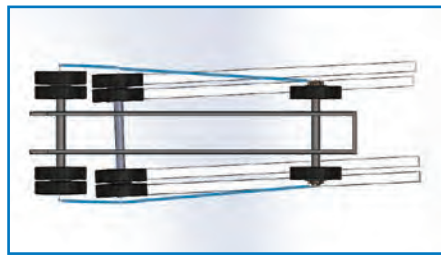

Figure A - Measuring from axle to axle will cause the operator to set both rear axles in a dog-tracking position if the first axle measured is offset or has different sized spacers.

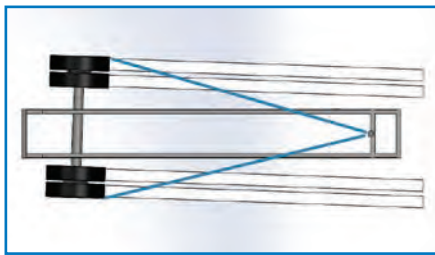

Figure B - Measuring from the king pin, or the center of the front frame, will have the same bad effects as Fig. A.

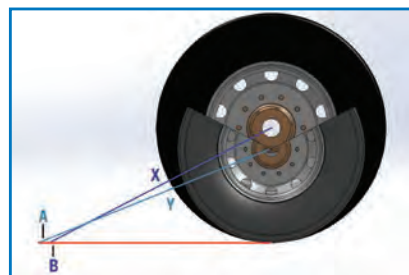
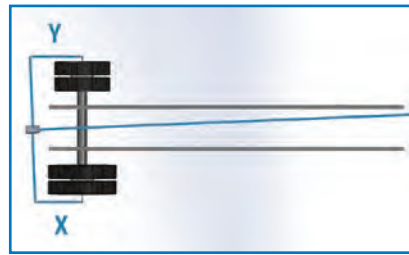

Figure E - Systems that represent axle position by measuring back from the center of the end of the axle can be fooled by different sized tires and/or even uneven tire inflation, which causes one side of the axle to be higher than the other. In the diagram above, lines X and Y are the same length. A and B show the distance back to the floor. The line AB is used to indicate the angle of the axle. As shown, it is misrepresented using this method.

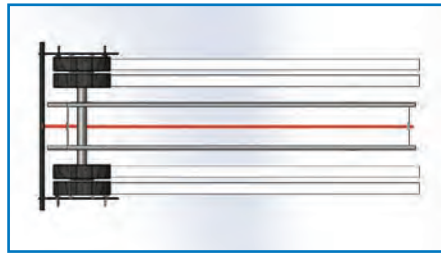

Figure C - With the Bee Line Laser Tandem Aligner, offset axles and axles with uneven spacers are set perfectly at 90° to the centerline of the vehicle. Additional axles are then simply set with a tram gauge.

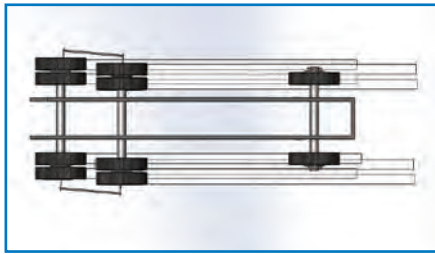

Figure D - An offset axle is automatically compensated for with Bee Line self-centering gauges. The operator aligns the laser to shoot through the rear gauge to the front target.

Trailer axles can be aligned by moving the cradles and beam to the trailer axles. The tandem target hangs from the king pin.



The 22000 can be calibrated in under two minutes with a simple process set up on any open floor space.



# Truck Axle Correction

Why measure if you don't correct?

*Bee Line's exclusive axle correction equipment is a must for the Truck Repair facility that wants to perform Complete Truck Alignment Service. Most passenger cars and light trucks have adjustments or aftermarket kits to adjust camber and caster to preferred specifications vs. OEM tolerances. It only makes sense to set a Heavy Duty Truck to preferred specifications also.*

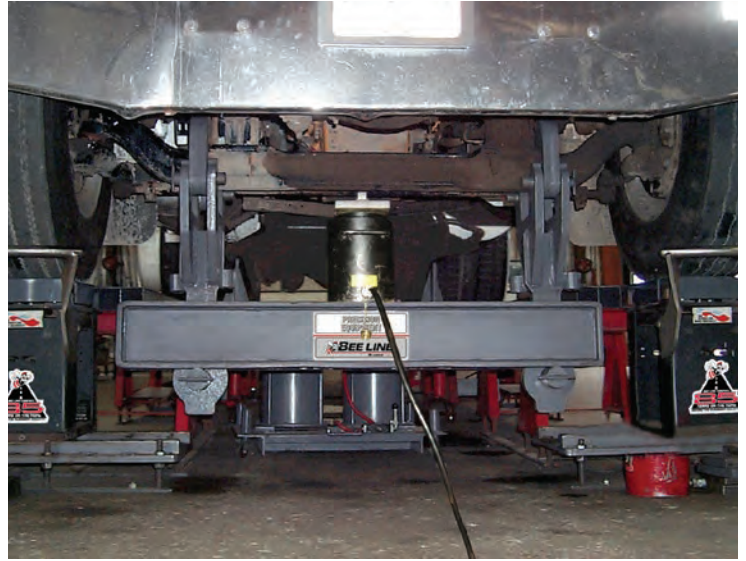

## Adjust axles to preferred specifications

Bee Line promotes preferred Bee Line Wheel Alignment Specifications vs. the OEM's very broad manufacturing tolerances. The Truck Maintenance Council (TMC) recognizes the importance of setting to a preferred target specification. The patented Bee Line Floating Beam allows you to adjust the axle to these preferred specifications.

The Floating Beam can be mounted parallel or at an angle to the axle, so the operator can remove both bends and twists to correct camber and caster. Specific tools were designed to be used safely with the beam. When paired with the Bee Line AA Machine, it takes only one technician to correct heavy-duty truck axles on the vehicle.



## Light-Medium Duty Tool Group

This Tool Group is designed for camber correction on trucks with 4,000 to 7,000 lb. axles, motor homes, and the Ford Super Duty with straight axles. The Tooling can be used with any wheel alignment machine and does not need a fixed beam between the turn tables. (Optional accessories include the 404100AL Aluminum Cross Bar and a clevis for Isuzu & Mitsubishi trucks.)



## Heavy Duty Tool Group

The Heavy Duty Tool Group is designed to correct caster and camber on Heavy Duty over-the-road trucks 12,000 lb. axles and up.

# Floating Beam System

## Negative Camber Correction - Both Sides

Negative Camber correction can be accomplished on both the right and left wheels simultaneously. If camber is too positive on both wheels and the relationship between the wheels is correct, the correction should be done as shown with the clevises equally centered on the axle. A single clevis can be used, but two clevises provide more stability during the set up. If unequal amounts of correction are required, a single clevis should be used and moved toward the side where the most correction is needed.



Negative Camber correction on both sides.

## Caster Twist

A Caster Twist is normally performed on the right side of the vehicle for accessibility and operator convenience. Use the setup shown with the outside twisting tool toward the rear of the vehicle to increase right caster relative to the left side. The outside twisting tool will be on the front side of the axle to make the right caster more negative. Then equally shim both sides if more or less caster is desired on both sides.

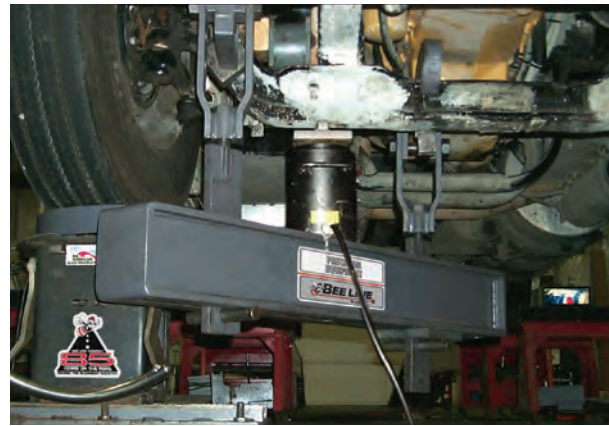

Caster twist correction setup.

## Corrections with Floating Beam System Lift and Pumps

Camber corrections are accomplished by using bridge hanger-type tie-downs to hold the axle in place while powerful Bee Line Hydraulic Rams (up to 125 tons) correct camber by pushing the axle upward.



All axle corrections can be performed with the Bee Line Floating Beam System. Included in the system is the Beam Lift that effortlessly positions the floating tool beam with hydraulic rams and connectors.



The Bee Line Electric Hydraulic Pumps are the finest pumps available on the market. The rams can operate together or separately. They operate on 115V, 10,000 PSI and require 30 amp service. The two stage system has a high volume first stage for output below 300 PSI. For efficiency, it automatically switches to a 10,000 PSI second stage. The electric pump unit is available with a solenoid control valve, or a hand held automatic release control switch valve.

# On The Floor Alignment

Conveniently Turn Any Bay into an Alignment Bay

*The Bee Line On The Floor Alignment System is a popular setup for trucking fleets and shops that perform routine alignment checks, but do not have a dedicated alignment bay. With our On The Floor System, any bay can be transformed quickly and easily into an alignment area in a matter of seconds.*



Bee Line's 7800 Auto-Lock HD Floor Jack is built for safety and durability.



Set the rear axles with computer accuracy using the 22000 Rear Axle Aligner.

## ADVANTAGES

### Fully gauge all alignment angles anywhere in your shop

All the same great gauging features of the LC7500 Series Computer Alignment System are available with our On The Floor System. This gives your shop the ability to accurately diagnose any misalignment condition and even correct the rear tracking and set the toe in any bay of your shop. On The Floor Alignment configuration is a fast, easy and less expensive way to make sure your trucks are performing at optimum efficiency.

### Build a foundation for the future

If more extensive misalignment conditions are detected, or if parts need to be replaced, the truck can be sent out to a facility with a complete Bee Line Alignment system for these corrections. Or you may choose to add additional Bee Line equipment and capability. You can do so at any time and continue to use the equipment that you have already invested in. When your business grows, this system will grow with you.

### Portable Cabinet System Includes:

#### LC7500 Gauging System

- Rolling cabinet
- 32" HD monitor
- Programmed alignment computer
- On-board printer
- Calibration fixture
- 2 alignment heads
- Pair of wheel mounts
- Portable Turn Plates
- 22000 Rear Axle Aligner

# Mobile Alignment

## Take Alignments to the Customer

Bee Line introduces the ultimate Mobile Alignment Package designed for maximum speed, accuracy and portability. Take alignments to the vehicle with a portable version of our acclaimed LC7500 series computer alignment gauging system. This system is ideal for gauging truck wheel alignment on location, inside or out and utilizes a laptop computer loaded with our WindSpeed 7500 software.



Take this compact, mobile system to the job site or use in any service bay. Full capability - all steer, drive and trailer axle measurements.



Mobile Alignments can be performed on any reasonably level surface inside or out. Our LC7500 alignment heads mount to the wheel with LC4195B.1 mounts and the wheel rests on wireless FPT8500 Turnplates.

## ADVANTAGES ...

### Take Alignments to the Customer

This system allows technicians to gauge toe, camber, caster, KPI and steering stops, as well as rear tracking on tractors and trailers when combined with the 22000 Rear Axle Aligner.

- Many full service commercial tire dealers and independent service shops have capitalized on providing a convenient alignment service at the customer's location. Utilizing custom trailers or vans allows them to transport all the gauging equipment and tools to perform the alignment on-site.
- Bee Line can help outfit mobile alignment vehicles with all the necessary equipment to make the job easy.

### Gauge More Vehicles per Day

- Diagnose alignment conditions and transport the vehicles to your shop if they need replacement parts or major adjustments.
- Save man hours by eliminating most transports to and from alignment bay.
- Save alignments on your laptop and print alignment results. Add a portable printer for printouts on-site.
- Batteries will supply power to the lasers for more than eight hours. A/C power is not necessary.

# Wheel Balancing

Balance the Entire Wheel Assembly for the Best Ride

The Smart Balancer is the most user-friendly wheel balancer on the market today. It replaces the old strobe-type balancers with a tool that anyone can use. From initial set up through the completion of the balance, the technician is prompted by a simple touch screen pad on the Smart Balancer 4088.



## ADVANTAGES

### On-The-Vehicle balancing is the official recommended method

On-the-vehicle wheel balancing refers to the Truck Maintenance Council's official recommended practice (RP 214C) of truck wheel assembly balancing. On-the-vehicle means the wheel is never removed from the truck during the balancing procedure. By leaving the wheel on, a technician not only balances the tire, he balances the hub and the drum in relationship to the truck's suspension. Balancing the entire wheel assembly provides a far more accurate, "smart" balance. *Simply put, there is no equal.*

### Make more money with a better balance in less time

The Smart Balancer takes the guesswork out of placing weights on the tire. In a few short spins, the touch screen illustrates the exact amount of weight and the exact position on the wheel the weight should be added. This process removes the chance for error and dramatically decreases the time it takes to balance each wheel.



1. A spinner brings the wheel up to speed. Includes safety shield.



2. A sensor measures wheel vibration.



3. The touch screen indicates the position and how much weight should be placed on the wheel.

| Part No. | SMART BALANCER                |
|----------|-------------------------------|
| 4088     | On-the Vehicle Wheel Balancer |

| Part No. | Wheel Spinners (Model Options:) |
|----------|---------------------------------|
| 2600     | 15 HP 220V 3 Phase              |
| 2600.1PH | 10 HP 220V 1 Phase              |
| 2600.440 | 15 HP 440V 3 Phase              |



# Alignment Accessories

Customize your Alignment System with Accessories



## FPT8500 Steel Portable Turn Plate

Our most popular turning aligner's sleek steel topped design is our sturdiest yet, capable of accepting 10,000 lbs. of weight. A convenient handle enables effortless positioning. The FPT8500 model weighs 35 lbs. per plate and is 14 1/2" wide x 19" long x 1 5/8" high. Long-life steel bearings, not plastic.

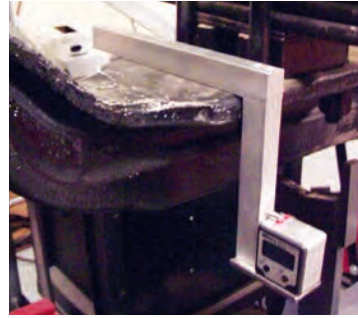

## 19020A Digital Spring Seat Gauge

Twisted spring seats cause trucks to shimmy and/or wander and also cause damage to the truck springs. The Bee Line 19020A Digital Spring Seat Gauge is designed to measure the difference, or

amount of twist, found between spring seats. If the axle is found to be twisted, the 405 or 406 floating beam systems can easily and accurately correct the problem.



## 100AL -100 Ton Aluminum Ram

Bee Line's Aluminum 100 Ton Ram weighs just 39 pounds, making it 61 pounds lighter than our Steel 100 Ton Ram, and still just as rugged. Made from high tech aluminum the rams generate a full 100 tons of force at 10,000 psi.



## LC4195B.1 Center Mount Wheel Mount

Designed for use on truck wheels, the Bee Line LC4195B.1 clamps securely to the front wheel studs or nuts when axle hub extends through rim. The lower bracket pivots and holds securely during and after a fast and accurate alignment.



## 404075 Confined Area Clevis

When making a positive camber correction to heavy duty axles, the universal design of this clevis eliminates the removal of the tie rod and in most cases, the drag link.



## 7800 Auto-Lock HD Floor Jack

Built for safety and durability. The self-locking mechanism automatically engages when the jack is raised, providing a safety advantage over other jacks on the market. It is the perfect tool for tire shops, heavy duty repair facilities, fleets and truck stops. 28,000 lb. capacity and lifts from 8 to 18 inches.



## 21130 Portable Rear Axle Aligner Cart

This mobile cart safely stores every piece of the 22000 Rear Axle Aligner, including the laser recharge unit and two optional FPT8500 Portable Turning Aligner Plates.



## 15000 Spring Lift

The Spring Lift is an innovative tool designed to lift suspension springs to safely and efficiently install caster shims. 10 ton ram not included.

## Hands-on Bee Line Training Courses

Bee Line Company offers training courses focused on the principles and techniques of performing computerized wheel alignment and truck frame correction. A fully equipped training center provides the ultimate learning environment. Enroll in Bee Line's training courses and take your first step toward advancement.

Register at [www.beeline-co.com](http://www.beeline-co.com) or call 800-728-7828



A **McLAUGHLIN** Company

For Parts, Service, Training or Technical Questions, Visit Us Online at

**beeline-co.com** or Call Toll Free **800-728-7828**

2700 62nd Street Court • Bettendorf, Iowa 52722

Fax 563-332-6517

BL601.3 - 07/16