



REDEFINING LASER ACCURACY

Product Catalog

Wheel Alignment | Elevated Solutions
Axle Correction

Table of



REDEFINING LASER ACCURACY

About Bee Line Company

Alignment Philosophy **6-9**

Front End Alignment

Computer Gauging Systems **10**

- LC7500 10-12
- LC7550 13
- LC7580 13

Mechanical Gauging Systems **14**

- Mechanical Gauges 14

Alignment Accessories **15-17**

Rear/Tandem Axle Alignment

Rear/Tandem Axle Alignment System **18**

- Tractor 18
- Trailer 19

Rear/Tandem Axle Alignment Accessories **20-21**

Mobile Alignment **22-23**

On The Floor Alignment **24-25**

Elevated Solutions/Configurations

Stationary **26**

- AA Machine 26-27
- Space Saver 28-29
- Pit Models 30-31
- Four-post Lift, Scissor Lift and Mobile Column Lift 32

Portable **33**

- Aluminum Runways 33

Components and Accessories **34-35**

Contents

Axle Correction Tools	36
Truck Axle Correction	38
Front Axle Tools	39
• 404	39
• 405BL	40
• 406HDL and 406L	41
• 406U and 407U	42
• 407CU and 407HU	43
Rear Axle Tools	44
• Tool Group 6	44
Pumps & Rams	
• Hydraulic Pumps	45
• Ram Specifications	46
• Ram Accessories	47
Frame Correction	48-49
Shop Equipment	
• 4088 Smart Balancer II	50
• King Pin Gauge EPM718	51
• 7700 Floor Jack	51
• 4010 Tire Runout Gauge	52
• Model 4000 Porta-Truer	52
Hands-on Training Opportunities	53
Index	
• Numerical Index by Part Number	54
• Alphabetical Index by Name	55





Bee Line is the world's leading manufacturer of Wheel Alignment, On-truck Tire Balancing and Frame Correction Equipment for Heavy Duty Trucks and Trailers. Located in Bettendorf, Iowa USA, Bee Line designs, manufactures and sells a variety of cutting edge products while providing unparalleled training and customer service to its valuable clients around the world.

*With an absolute commitment to superior products, Bee Line utilizes the finest materials, advanced technologies and proven processes to deliver long-lasting, reliable performance. Bee Line applies the technology and expertise gained in the very demanding commercial vehicle maintenance industry to offer a full range of products to service every application. Bee Line offers the **ONLY COMPLETE Truck Alignment System** that allows you to accurately measure AND correct toe, caster, camber and KPI to assure optimum vehicle performance and driver handling.*

Bee Line built its exceptional reputation by producing state-of-the-art, quality equipment and innovating with every challenge. Continuous process improvement, providing the very best in testing, maintenance and alignment technology results in the innovative products which fulfill our ambitious standards. Our strategy continues to be a model for flexibility, emphasizing technological developments and problem solving to meet the ever-changing market conditions.

Leaders in Quality

Customers want to be confident that they are doing business with an organization that can meet or exceed their requirements in a timely manner. Because it is an internationally recognized quality management system, **ISO 9001:2015** certification gives Bee Line customers a reason to have that confidence. Our products guarantee the highest in precision and quality, resulting in the finest heavy duty workshop equipment on the market.



Leaders in Innovation

Being an innovation leader requires a highly qualified, skilled and inspired staff. Careful personnel planning, internal and external collaboration and on-going research ensures that industry standards are constantly surpassed. In-house design and assembly, along with an internal software development team and superior manufacturing capabilities, make Bee Line uniquely self-reliant.



100 Years Experience. Proven Results.



Leaders in Expertise

Before World War I, George L. Hunt invented and marketed many of the early tools for the maintenance and repair field. As the need for better methods of wheel alignment became necessary, the George L. Hunt Company began developing “on vehicle” wheel alignment and correction tools.

By early 1920, the first Frame Correction Machine was designed and built and in 1927, the company name was changed from the George L. Hunt Company to Bee Line Company. In 1979, Bee Line became a McLaughlin Company, thus continuing the tradition of product quality and customer service.

The introduction of superior Bee Line Systems for Wheel Alignment and Truck Frame Straightening led to world leadership in the commercial vehicle markets. This Bee Line equipment has enabled millions of trucks and trailers to return to the highway as safe, efficient and productive vehicles.

Today Bee Line applies the technology and expertise gained in the very demanding commercial vehicle industry to offer a full range of products to service commercial vehicles in over-the-road, off-road, military and specialty applications. By answering the needs of a changing industry for more than a century, Bee Line will continue to be the leader of the complete alignment market and the company setting the trends in the future.



Alignment Basics



Alignment Philosophy

Although Wheel Alignment is often overlooked on the preventative maintenance programs in the trucking industry, more importance is increasingly being placed on the cost savings and handling characteristics of routine complete alignments. Fleet executives are continually putting more emphasis on maintaining skilled drivers by performing alignments, which create considerable fuel and tire savings while improving drivability.

Studies continue to find that only setting the toe and tracking on vehicles is **not a complete solution**. Camber is recognized as a major contributor to tire wear and caster is a major contributor to suspension life and drivability.

Bee Line is a leading manufacturer of equipment that **MEASURES AND CORRECTS** caster and camber - resulting in **TOTAL** wheel alignment. The company manufactures heavy duty truck frame correction equipment in addition to the alignment equipment, thus providing a complete solution. While vehicles continue to get lower to the ground and axles continue to get stronger, Bee Line produces new products to keep up with these trends. Bee Line systems are designed to fit each shop's specific needs and expand to accommodate changing conditions.

ALIGNMENT BENEFITS

Proper wheel alignments result in:

- Increased tire performance – up to 30% – and even more miles.
- Decreased fuel consumption – 1 to 3% better fuel mileage.
- Improved drivability – increased driver satisfaction / less fatigue.
- Improved performance from suspension parts.

What Is Proper Alignment?

Positioning the interrelated angles of a front suspension and rear axle for maximum tire life, lower rolling resistance and ease of steering. Ideally, when a truck is traveling in a straight line, all of the axles are parallel – and perpendicular to the vehicle centerline – and all of the tires are rolling in a straight line too.

Alignment isn't just for tractor steer and drive tires – it's for trailer tandems too. Misaligned trailer axles will cause irregular wear on the trailer tires and the power unit tires.

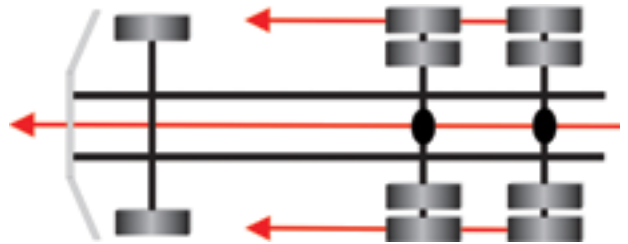

Alignment Basics

Leading Wheel Alignment Factors



Wheel alignment is the positioning of the interrelated angles of a front suspension, rear axle or housing to give the maximum amount of tire life, steering ease, steering stability and increased life of suspension components. Improper wheel alignment results in excessive or irregular tire wear, hard steering, poor drivability and premature failure of suspension parts.

Several alignment factors must be considered in order to achieve proper wheel alignment. The top four factors are Toe, Tracking, Camber and Caster.

Toe and Tracking

Toe and tracking are the two most critical alignment settings for front end tire wear.

Bee Line gauging equipment incorporates lasers to measure for proper steer axle toe. Toe is adjustable to reduce tire wear and reduce (eliminate) shimmy (vibration) in the steering wheel. Excess or too little toe will make the front wheels fight each other, thus increasing wear. An out-of-toe condition leads to rapid inside or outside wear of steer tires. Tracking misalignment will also cause irregular tire wear in the steer tires. Tracking, or thrust, is gauged relative to the vehicle centerline.

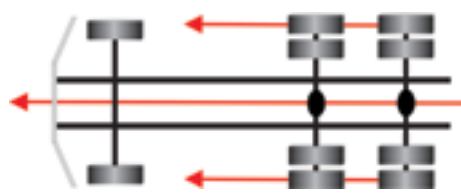

Total Toe-in: $A < B$
Total Toe-out: $A > B$
Zero Toe: $A = B$



The Bee Line method uses the chassis center line as a reference for optimum vehicle performance.



Tracking refers to rear axles. They must be parallel to each other and perpendicular to the center line. If not, the driver must compensate by holding the steering wheel off-center, causing rapid and irregular steer tire wear.

Toe refers to steer tires either pointing inward or outward.

Camber and Caster

Camber and Caster are the third and fourth most critical alignment settings for front end tire wear.

Camber is defined as the inward or outward tilt of the top of the wheel. It is important for several reasons; the main purpose of camber is to keep the tire flat on the road while the vehicle is loaded and in motion. If camber is excessive, it will create shoulder wear. Caster is the forward or rearward tilt of the king pin. Extreme caster settings can cause handling problems leading to driver fatigue.

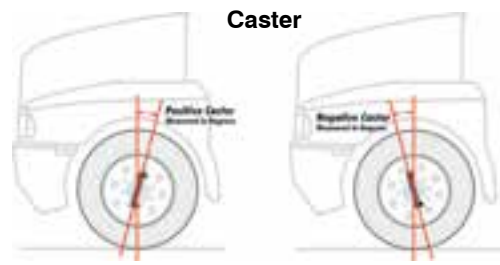
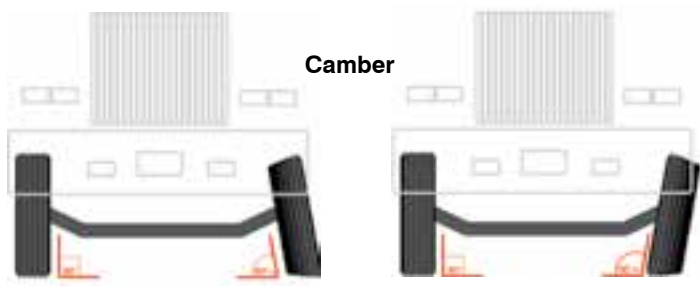

Alignment Solutions

Total Vehicle Wheel Alignment



In the Heavy Duty Truck Alignment industry there are several concepts that establish accurate truck alignment to achieve maximum efficiency. Alignment equipment on the market today varies widely in areas of overall design, technology and the extent of capabilities. Inexpensive and basic systems may only use mechanical equipment that depends on technician interpretation to gauge some alignment angles. More expensive equipment may take only a few basic alignment measurements and then input the findings into a computer to analyze the alignment condition. Even some computerized alignment equipment still may only allow you to measure and adjust basic toe and tracking errors.

Bee Line recognized a long time ago that measurement and correction of all the major alignment angles is necessary to achieve maximum truck efficiency. **That is why Bee Line promotes the concept of "Total Vehicle Wheel Alignment" to extend tire life, maximize fuel efficiency and improve vehicle handling.**

Total Vehicle Wheel Alignment means measuring and correcting all alignment angles, not just toe and rear tracking. What good is it knowing the truck is out of alignment if you cannot correct the problems? This means not just correcting toe and/or rear tracking, but also **correcting camber and caster.**

TOTAL SOLUTION

"With the ability to correct toe, rear tracking, camber and caster, Bee Line offers the only heavy duty Total Vehicle Wheel Alignment Solution."



Advanced Aligner Runway System

The Bee Line Advanced Aligner Runway machine and our alignment tooling is designed to allow a shop to perform all necessary alignment corrections. The machine places the truck at a comfortable working height, either in a pit or above ground. It allows room to make adjustments not only to toe and tracking, but also camber and caster. There is no fixed beam or equipment in the way to hinder access or make it difficult to work on the vehicle.



Suspension Inspection

The first step in a professional alignment is to raise the vehicle and inspect the suspension for problems like damaged springs, worn king pins, loose wheel bearings or worn steering linkage. Without raising the vehicle, these problems can go unnoticed and continue to cause tire wear and handling problems. Using a Bee Line alignment machine along with our heavy duty air jack allows you space to inspect the vehicle. Our popular Advanced Aligner Runway machine is available in a variety of lengths and widths from two sections to whatever meets your needs. Once on the runway, the heavy duty air jack is used to lift the front of the vehicle. Inspection, maintenance and runout can easily be performed.

Computer Alignment System

Bee Line's state-of-the-art computerized alignment system utilizes lasers, which are more accurate than manual or infrared sensors. The bright laser beams are highly visible and show any alignment errors on the vehicle. Bee Line lasers provide the most accurate alignment readings on the market today. While most systems only measure to one hundredths of an inch (0.01), Bee Line uses a system capable of measuring alignment variables to five thousandths of an inch (0.005).

All corrections and adjustments to a vehicle's alignment are done with a "live" reading. The readings for toe, rear tracking and camber are shown on the computer screen or a wireless Remote Display and reflect all changes as corrections are being made to ensure accuracy.

Calibration is built-in on Bee Line equipment. Calibration is an important part of any alignment system and should be done frequently to ensure accurate alignment readings. Bee Line's equipment has built in calibration capability and can be calibrated by the operator at any time in just a few minutes. There is **no long wait** between calibrations and **no extra expense** while waiting for an outside party to come and calibrate the equipment.



Built-in calibration capability minimizes downtime.

Axle Correction Tools

Complete alignment does not stop with a measuring system. Why take readings if they are not used? Improper camber causes tire wear and improper caster causes handling problems. To correct caster and camber on trucks, Bee Line developed the "Floating Beam System" and when used with the Bee Line AA machine, one technician can correct heavy duty truck axles right on the vehicle.

Bee Line's patented camber tooling can correct out of tolerance camber on all axle sizes and also correct caster due to axle twist. The floating beam system is designed to be easily attached to the vehicle axle for corrections and removed and placed out of the way when the correction is finished. Special Bee Line Spring Lift also allows easy removal and replacement of caster wedges.



To correct caster and camber on trucks, Bee Line developed the "Floating Beam System."

Rear Axle Aligner

Complete your total alignment system with a 22000 Rear Axle Aligner. For a vehicle to track properly, the rear axles must be perpendicular to the vehicle's centerline and parallel to each other. The Rear Axle Aligner is fast, accurate and easy to learn and use. A technician can set up the system and take all necessary measurements in less than five minutes. If adjustments are needed, they can be made with the Rear Axle Aligner in place, using it as a guide for the adjustment.



The Rear Axle Aligner is fast, accurate and easy to learn and use.

Laser Guided Alignment System

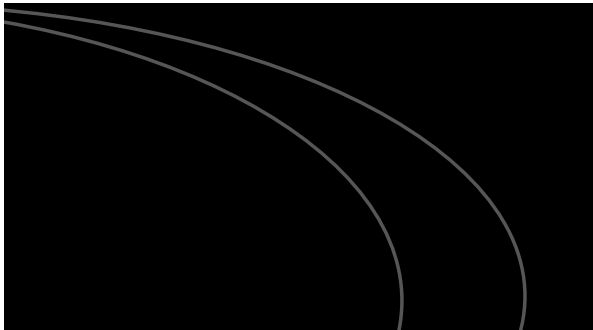

LC7500 Computer Alignment System

The LC7500 Laser Guided Computer Wheel Alignment System was developed to significantly lower your cost of performing alignments, increase productivity therefore improving profit potential.

Advanced features and functionality are based on extensive in-house research, a thorough understanding of user needs and invaluable suggestions and feedback received from our customers.

The LC7500 is unique to the industry because it gives the technician the ability to continually maintain the precision of most Bee Line alignment equipment. **The entire system can be calibrated in a few minutes right in your shop.** Exclusively through Bee Line, there is no downtime and no additional bills from service reps to maintain the accuracy of your alignment system.

Windows-based WindSpeed 7500 software has integrated **help videos and service manuals** that are uncomplicated and straightforward, making training simple. Several help videos appear in the help section that guide the user through the specific procedure. If more complex assistance is needed, Bee Line provides **remote diagnostics**. Our technology experts virtually access your machine from our headquarters to speed up diagnosis and offer a solution.

This system allows technicians to gauge toe, camber, caster, KPI and steering stops, as well as rear tracking on tractors and trailers when combined with the 22000 Rear Axle Aligner.

Using cutting edge technologies, Bee Line has engineered the LC7500 to provide the lowest cost of ownership of any system on the market today.

ALIGNMENT SOFTWARE



WIND SPEED 7500
ALIGNMENT SOFTWARE



Interactive alignment heads are a "workstation" for the technician. Wireless up to 1,000 feet.

Redefining Laser Accuracy from the Inside Out

Free Software Updates

Minimize Downtime

- Bee Line Windows-based software works with any PC.

Increased Visibility

- An impressive 32" HD Monitor is easily visible at a greater distance.

Superior Design Maximizes Efficiency

- Technician becomes more productive
- Heads stored vertically to minimize risk of damage
- Stable cabinet prevents tipping
- Printer storage drawer built-in

Built-in Calibration fixtures and on-board help videos show the technician how to easily calibrate the equipment in the shop.

- No service call required.
- No additional cost.

On-Board Assist/Remote Access

- F1 Help Section
- Training Videos
- Virtual Software Updates
- Minimizes Downtime and Costs

Improved Durability

- Fewer moving parts in the laser assembly reduces wear, loss of accuracy and the need for repair.

Accuracy

- More than 1800 sensors calculate the laser strike to an accuracy of 1/1000th of a degree.



When a step is illustrated on the computer monitor...



...the same step is displayed with live readings on the head.

Front End Alignment

LC7500 Series Features:

- LCD monitors built into wireless alignment heads with live readings save overall alignment time.
- Lasers instantly find optimum target on all target boards to ensure accurate and fast measurements.
- User friendly built-in system calibration fixture allows the user to calibrate system accuracy in minutes.
- Advanced steering wheel centering process applies the tracking calculation to the front toe, allowing the vehicle to be accurately aligned and the steering wheel centered on the first attempt.
- PC with Microsoft Windows based software, 32 inch monitor and color printer.
- Lightweight lithium ion batteries power unit for 10 hours of continuous use in each alignment head.
- Power-save feature automatically powers down alignment heads that are left on unintentionally.

Key Product Attributes 7500 Series

Each Bee Line gauging system within the 7500 Series share similar features, but are individually designed to meet specific needs. The products within the series include:

- LC7500
- LC7550
- LC7580

Superior design, smarter technology increases efficiency and speed

The LC7500 computer alignment system redefines laser accuracy from the inside, out. Technological refinements, such as advanced target board sensors and processors, allow for quicker calculations and more immediate, precise laser positioning than could previously be performed in your shop. The result: faster, more accurate alignment.

An impressive 32-inch TV monitor is more user-friendly than ever, with software screens that have been redesigned to maximize font size for ease of viewing and drop-down menus that are a snap to navigate. Pop-up reminders, help screens and help videos are available to assist those with questions. For mobile technicians, the WindSpeed 7500 software runs on a powerful laptop computer that obtains readings exactly like any other Bee Line computerized alignment system.

Unmatched productivity

Faster processing, extraordinary accuracy and increased speed all come together in the LC7500 Series to deliver the ultimate return on your investment by enhancing productivity. Users have performed at least one more alignment per day, generating additional revenue each week – all without adding more technicians or working overtime.

Front End Alignment

LC7550 & LC7580



LC7550 - Our Mobile Alignment laser guided computer alignment system features the acclaimed WindSpeed 7500 software running on a powerful Bee Line laptop computer.

Technicians obtain readings exactly like any other Bee Line computerized alignment system. WindSpeed 7500 instructs the technician through each step of the process and displays live readings during adjustments. The data for each alignment performed is saved to the hard drive and can be printed for each customer showing before-and-after results. Gyro equipped heads feature color LCD screens that guide the technician through the alignment process. Each head includes no seek lasers that dramatically speed up the gauging process.

LC7580 - Adaptability for ALL vehicles

The Bee Line LC7580 Laser computer wheel alignment system revolutionizes Bee Line four wheel alignment and allows your shop to align independent rear suspension vehicles, twin steer vehicles and everything in between. It is the ultimate Bee Line Alignment machine.

The LC7580 continues the excellence of laser accurate measurements up to 1/1000th of an inch by using a no-seek laser to instantly produce live measurements that are consistently repeatable. When making corrections, live readings guide the technician in achieving optimum alignment settings.

The LC7580 comes standard with four alignment heads that accurately and efficiently align all passenger vehicles. The LC7580 features Bee Line's WindSpeed 7500 Alignment software that accommodates alignments on commercial vehicles utilizing two LC7580 alignment heads and our optional proven 22000 Rear Axle Aligner. The result is one computer alignment system that can align any vehicle that comes into your shop.



Caster-Camber Gauges With 2-Dial Run-Out Eliminator

The Bee Line 18305 and 19305 gauges come complete with these great features:

- Bee Line Micrometer Dial, which has proven itself time and again in the industry as the most accurate and easy to read mechanical Caster-Camber gauge.
- Complete horizontal and vertical run-out compensation with exclusive two dial system eliminates any guesswork.
- The cam system locks easily and securely to bead, fellow or any other part of the rim or wheel.
- The reversible advancer will mount securely to the inside or the outside of the rim.
- Quality construction of lightweight durable materials ensure a long dependable life.



Part No. 18305 Caster-Camber Gauge - Cars*

Fits car, light truck and SUV wheels from 12" through 18". These gauges are designed to fit most recessed or partially enclosed wheels such as those commonly found on motorhomes/RVs.

Part No. 19305 Caster-Camber Gauge - Trucks*

Comes complete with necessary foot extensions (PN 19345) to fit truck wheels through 24".

**Part No. 18334 Calibration Bar - Need Qty of 1 for use with 18305 and 19305 Mechanical Caster Camber Gauges.*

Part No. 2300 Toe-In Gauge

Model 2300 for trucks extends to a 96" (243.84 cm) width with adjustable legs that extend up to 17½" (44.45 cm) high.



Part No. 1790 Tire Scribe Gauge

To determine a precise reading of toe, manually use the tire scribe gauge and spin each of the front tires. The 1790 is spring loaded to easily scribe any size tire. It can also be used for checking wheel run-out.



Front End Alignment

Alignment Accessories



Part No. FP7860 Rear Slip Plates

For a free sideways motion when making rear measurements and adjustments. Built with a triple row of steel roller bearings for a long life. These plates also have a convenient handle for easy positioning. The size of the Rear Slip Plate is 14" wide x 13 1/2" long.



Part No. FPT8000 Aluminum Portable Turn Plate

The free floating design of this portable turning aligner – complete with a convenient handle for easy positioning – allows wheels to be easily and smoothly maneuvered during the alignment process with help from heavy duty steel ball bearings positioned underneath the rust-resistant aluminum plate. The FPT8000 sits slightly higher than its successor with dimensions of 15 1/2" wide x 17" long x 2 1/8" high, and is rated to accept 10,000 pounds.



Part No. FPT8500 Steel Portable Turn Plate

Our most popular turning aligner's sleek steel topped design is our sturdiest yet, capable of accepting a substantial 10,000 pounds of weight. A convenient handle enables effortless positioning, and the free floating turning plate resting on steel ball bearings allows for superior wheel mobility during the alignment process. The FPT8500 model weighs 35 pounds per plate and is 14 1/2" wide x 19" long x 1 5/8" high.



Part No. FPT9500 Heavy Duty Turn Plate

The steel-topped portable Heavy Duty Turn Plate has the same unique king pin action as the full-sized turning aligner and allows a wide turning angle to accurately align steer tires. At 74 pounds per plate, the FPT9500 is designed to handle larger loads – up to 16,000 pounds. The Heavy Duty Turn Plate measures 24" wide x 18" long x 2 1/8" high and can be used on the floor or on the machine.



Part No. LC4101.1 Cam Advancer Wheel Mount

This ratcheting style wheel mount has a long history of reliability and functionality. The LC4101.1 converts rapidly from small to large rims for shops aligning a wide range of vehicles.

Front End Alignment



Alignment Accessories

Part No. LC4102.1 Self-Centering Wheel Mount

The LC4102.1 for heavy trucks (and the BLC250.1 Self Centering Wheel Mounts for automobiles) provides users with the self-centering capability. Self-centering mounts maintain the computer head balance to prevent the wheel and head from turning when lowering the vehicle. Wheel turning during lowering has the potential to damage the head and unfavorably affect the accuracy of the alignment. The BLC250.1 fits wheels with a rim diameter of 12" to 20" and the LC4102.1 fits wheels with a rim diameter of 17" to 29.5".

Part No. LC4195B.1 Center Mount Wheel Mount

Designed for use on truck wheels with a 10 hole pattern, the Bee Line LC4195B.1 holds standard Bee Line computer heads. The LC4195B.1 wheel mount clamps securely to the front wheel studs or nuts when axle hub extends through rim. The lower bracket pivots to produce true 3 point contact and holds securely during and after run-out, which facilitates a fast and accurate alignment.

Part No. Spring Seat Gauges

19020 Spring Seat Gauge

19020A Digital Spring Seat Gauge

Twisted spring seats can cause trucks to shimmy and/or wander and also cause damage to the truck springs. The Bee Line 19020A Digital Spring Seat Gauge is designed to measure the difference or amount of twist found between spring seats. If the axle is found to be twisted, the 405 or 406 floating beam systems can easily and accurately correct the problem. This gauge can also be used to measure caster wedges (Shims).

Part No. EPM715 Tread Depth Gauge

An optional Tread Depth Gauge allows technicians to measure tire wear for every tire on virtually every type of vehicle. The tire wear data is stored in WindSpeed 7500 Software and, if desired, tread depth measurements can also be taken as a stand-alone from an alignment.

Part No. 15000 Spring Lift

Used to safely install or remove caster shims.
(10 ton ram not included)

Front End Alignment

Alignment Accessories

Part No. EPM720 Remote Display

The new Remote Display is simply a must-have tool for the LC7500 Computer Alignment System. Users have grown accustomed to the advantages of color LCD screens built into the Alignment Heads. The Remote Display puts those same advantages in a lightweight wireless package that a technician can use anywhere.



Part No. EPE261W Wall Charging Station

Bee Line offers the Wall Charging Station, which stores and recharges the wireless head and tube unit.



Part No. LC7060 Portable Case

As with any precision equipment, the transport of the alignment system components can be harder on the equipment than the actual use. This portable carrying case reduces the risk of damage and provides secure storage for our Gyro Alignment Heads, Wireless Radios, Charging Units and more.



Part No. Spindle Gauges

- 19356 Car Gauge
- 19358 Truck Attachment

Spindle Run-Out Gauges will detect bent spindles by detecting run-out of the bearing seats. Run-out is defined as the maximum change in the dial indicator from the initial zero position during one revolution of the gauge.



Part No. 7700 Floor Jack*

The 7700 can lift vehicles from any two separate points of contact along its 33-inch beam. This feature alone produces a far greater degree of safety than the conventional single point floor jack. An operator has the option to utilize different sized axle supports that slide to any position on the beam and guarantee the desired lift.



*Optional Accessory 7710 Set of 2 trailer extensions.

Centerline Alignment for Rear Axles



The wheel cradles feature rack and pinion frame gauges that assure accuracy when determining the axle center.

Rear Tandem/Axle Alignment:

- Fast, simple to use
- Tractor or Trailer gauging
- Gauge to vehicle centerline
- Versatile – use with computer or without
- Eliminate “dog tracking”



Rear/Tandem Axle Alignment



In order for a vehicle to achieve proper tracking, the wheels must travel parallel to the centerline. All rear axles, including offset axles and axles with different tire spacers or different size tires are set perfectly at 90 degrees to the centerline of the vehicle regardless of whether the chassis is centered over the axle.

If the rear axles are not traveling 90 degrees to the centerline of the vehicle, there will be excessive tire wear on the front and rear tires.

The rear axle alignment is usually thought of as the second most critical tire wearing angle, although the rear axle tracking can be the most costly due to it causing premature tire wear on all of the vehicle's tires – front and rear. Proper rear axle tracking will also increase fuel mileage since wheel dragging is relieved.

The Proven Bee Line self-centering Wheel Cradles assure the correct position of the laser when seated on the cradles in relation to the axle. Wheel Cradles eliminate the need for run-out and raising the vehicle off the floor, allowing the operator to gauge the suspension alignment in its operational position.

**Save up to 30% on tire costs
and up to 2% on fuel costs.**



The laser beam is aimed forward in a line identical to the axle's thrust line and strikes the front target, which measures the amount of axle error from the centerline of the vehicle.

Achieve Proper Tracking

Rear/Tandem Axle Alignment System

Bee Line 22000 Rear Axle Aligner

With the newly redesigned Bee Line 22000 Portable Rear Axle Aligner, you can take rear axle alignment to your customers' shops, terminals or wherever they might be located.

The 22000 can be used as a stand-alone manual gauging system for tractors and trailers or as a part of our computerized gauging system. The design of the equipment allows the axles to be aligned to the center-line of the vehicle, ensuring maximum tire life and the safest vehicle operation. Self-centering frame gauges and a calibrated laser provide the highest level of accuracy on the market.

Tracking error can be diagnosed in less than five minutes. The 22000 is the latest version of our intelligent, time tested design that continues to be the industry benchmark for tractor and trailer axle alignment.



The proven 22000 lets you accurately position your rear axles perpendicular to the vehicle's centerline, allowing the wheels to travel in a straight line.

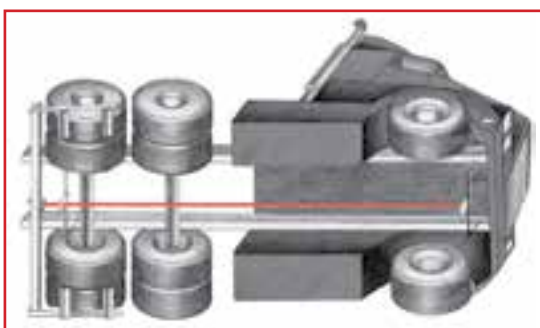

Trailer Tracking

Trailer cone effect with driver steering correction leading truck to pull.

Trailer cone effect results in:

- Tractor steer tires will feather/razor edge towards the direction of pull.
- Once feathering is established in front steer tires, the tires should be replaced or trued before a complete alignment.

Many fleets disregard trailer axle misalignment, but it can also cause irregular steer tire wear. Why? If the trailer is tracking in one direction instead of straight ahead, the driver must constantly steer the truck in the opposite direction. This will cause a wear pattern on the steers that looks like drive axle misalignment.

Available System configurations listed on page 21.

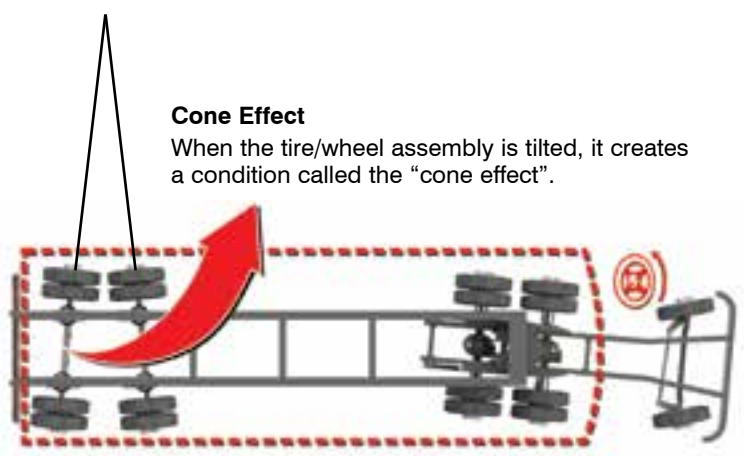

Rear/Tandem Axle Alignment System

Rear/Tandem Axle Alignment Accessories



Part No. 21130 Portable Rear Axle Aligner Cart

The Portable Rear Axle Aligner Cart safely stores every piece of the 22000 Rear Axle Aligner, including the laser recharging unit and two optional FPT8500 Floor Plates. The compact design allows shops to save valuable space while keeping their equipment away from any danger of being damaged. When an alignment is required, simply grab the handles and roll it to where it is needed. Each piece of equipment can be easily removed and returned before and after the alignment. The 21130 is a time and money saver for any shop that performs Rear Axle Alignments with our 22000 Portable Rear Axle Aligner.



(Standard with computer system)

Part No. EPM940 Electronic Target

Laser photo cell receiver allows computer entry of Rear Axle Alignment data when used with the computer alignment system. The electronic target hangs from the king pin via the King Pin EZ Loc extension (PN19320). (Used with 19225CL, 21000 or 22000)



18410E

Part No. 18410A Mechanical Tram Gauge

This tram gauge can be used where precise tram readings are a must. Easily measure the parallelism of your tandem axle with this gauge. Comes standard with 22000.

Part No. 18410E Electronic Tram Gauge (Upgrade)

The Telescoping Electronic Tram Gauge incorporates several new features that simplify the gauging process, including a lightweight design, exceptional accuracy and repeatability and a built-in electronic digital scale.

Part No. 18410XL Extended Length Telescoping Tram Gauge

Extendable up to 140 inches.



Part No. 19290 Dolly Aligner Target

Dolly target assembly is used to adjust tracking on dollies or trailers with a pintle-style hitch.

Rear/Tandem Axle Alignment System

Rear/Tandem Axle Alignment Accessories



Part No. Web / Flange Feelers

- 21320** 4" Web / Flange Feelers
- 21321** 8" Web / Flange Feelers

The web feelers allow accurate gauging of the rails even when a uniform flange is not available. These instruments enable longer reach and more surface to grab the frame web.

Part No. 19968 Trailer Centering Gauge



A trailer centering gauge can be used with the Electronic target when gauging trailers. Vise-grip clamps attach to the outer edge of the trailer. Designed for use when the tractor and trailer are attached.

Alternative System Configurations

For trailer axle only alignment, pair the 22000 Bee Line Tandem Axle Aligner with a computer system and you will be equipped with all of the components needed to communicate and store the readings.

TLC750W Cabinet Computer System

Cabinet setup for use with the 22000 tandem aligner that has a monitor, keyboard, computer, and printer on-board. The system also includes an electronic tandem target, programming cable and a network cable - all needed to communicate and store the readings.



PLC750W Laptop Computer System

Laptop setup for use with the 22000 tandem aligner. The system includes an electronic tandem target, programming cable, network cable, AC Interface, Radio Transceiver, serial cables and power supplies - all needed to communicate and store the readings on the laptop.



Taking Alignments to the Vehicle



Mobile Alignment

- Portable - Take to the job site or use in the service bay
- Full capability - all steer, drive and trailer axle measurements

Mobile Alignment

Bee Line introduces the ultimate Mobile Alignment Package designed for maximum speed, accuracy and portability. Take alignments to the vehicle with a portable version of our acclaimed LC7500 series computer alignment gauging system. This system is ideal for gauging truck wheel alignment on location, inside or out and utilizes a laptop computer loaded with our WindSpeed 7500 software. This system allows technicians to gauge toe, camber, caster, KPI and steering stops, as well as rear tracking on tractors and trailers when combined with the 22000 Rear Axle Aligner.

Take Alignments to the Customer

Many full service commercial tire dealers and independent service shops have capitalized on providing a convenient alignment service at the customer's location. Utilizing custom trailers or vans allows them to store all the gauging equipment and tools to perform the alignment on-site. Bee Line can help outfit mobile alignment vehicles with all the necessary equipment to make the job easy.

Precision Calibration Fixtures

Like all Bee Line equipment, we give you the ability to maintain the precision of your mobile alignment system. Unlike our competition, our entire system can be calibrated in a few minutes by any technician on location or in the shop.

*To request an
on-site demonstration
of this product*

Call 1-800-728-7828

Taking Alignments to the Vehicle

7700 Floor Jack

Outstanding design and performance make our 7700 the ultimate Air/ Hydraulic floor jack on the market for your alignment shop.



LC4195B.1 Center Mount Wheel Mount

Our most popular mount. Extremely lightweight and simple to install. The lower bracket pivots to produce true 3 point contact and holds securely during and after run-out, which facilitates a fast and accurate alignment.

FPT8500 Portable Turn Plate

These heavy duty steel-topped plates are wireless thanks to our Gyro Alignment Heads. They can rest on a flat, solid surface or on our optional portable aluminum runways.

LC7550 Portable Alignment System

Mobile Alignments can be performed on any reasonably level surface inside or out. Alignment heads mount to the wheel with LC4195B.1 mounts and the tire rests on wireless FPT8500 Turn Plates.

LC7060 Portable Case

Provides secure storage for our Gyro Alignment Heads, wireless radios, charging units and more.

402600.CTA Aluminum Runway with Turning Aligner Cut-Out

402601 Portable Aluminum Ramp

Bee Line adds a new dimension to Portable alignments by designing aluminum runways that raise vehicles 8 inches off shop floors. This extra clearance allows access under the vehicle when making alignment adjustments and also when performing general vehicle maintenance.



Complete Alignment Checks with No Dedicated Alignment Bay



On the Floor Features:

- Cabinet work station on wheels – can be moved to any bay
- Full capability – all steer, drive and trailer axle measurements

On the Floor Alignment

The Bee Line On The Floor Alignment configuration is a popular setup for trucking fleets and shops that perform routine alignment checks but do not have a dedicated alignment bay. When needed, the alignment system can be easily rolled into the bay.

All the same great gauging features of the LC7500 Series Computer Alignment System are available with our On The Floor System. This gives your shop the ability to accurately diagnose any misalignment condition and even correct the rear



tracking and set the toe in any bay of your shop. If more extensive misalignment conditions are detected or if parts need to be replaced, the truck can be sent out to a facility with a complete Bee Line Alignment system for these corrections. Our On The Floor Alignment configuration is a fast, easy and less expensive way to make sure your trucks are performing at optimum efficiency.

*A fast, easy and
portable alternative.*

**Call 1-800-728-7828
for more information**

Complete Alignment Checks with No Dedicated Bay

LC7500 Alignment Gauging System

The LC7500 computer alignment system redefines laser accuracy, from the inside, out.



FPT8500 Portable Turn Plates

These lightweight yet durable plates are wireless thanks to our new Gyro Alignment Heads. They can rest on level ground or on our runways.

7700 Floor Jack

Outstanding design and performance make our 7700 the ultimate Air/ Hydraulic floor jack on the market for your alignment shop.

22000 Portable Rear Axle Aligner

Centerline alignment ensures the vehicle operates in the optimal condition with the least resistance for maximum tire performance, fuel efficiency and handling.



EPM720 Remote Display

The Remote Display is simply a must-have tool for the LC7500 Computer Alignment System. The Remote Display puts those same advantages in a lightweight wireless package that a technician can use anywhere.

LC7500 WAR EXTENDED WARRANTY

Protect Your Investment

FEATURED PRODUCT



7700 Floor Jack

The 7700 can lift vehicles from any two separate points of contact along its 33-inch beam. This feature alone produces a far greater degree of safety than the conventional single point floor jack. An operator has the option to utilize different sized axle supports that slide to any position on the beam and guarantee the desired lift needed whether the truck is on the floor, on portable turn plates or on portable runways. Converting the jack into a single point floor jack for operations such as wheel balancing can be done by simply sliding one of the short axle supports to the center of the beam.

Elevated Solutions/ Configurations



Advanced Aligner Runway Features:

- AA Machine provides great access
- Special tooling allows technician to correct the axle and return camber or caster to spec
- Value added service and differentiated capability

Stationary

Advanced Aligner Runways

Bee Line Advanced Aligners are multi-functional work-horses for alignment shops, body shops, garages, dealer service centers, tire centers and fleets. They handle all makes of small cars through the heaviest trucks. Each Advanced Aligner features a choice of 24" or 30" Runway Legs to achieve the best working height.

Bee Line Advanced Aligners accommodate vehicles with tread widths from 39" to 94" or 54" to 108". Numerous pit or above ground models are available for alignments from either direction.

Mixing and matching Bee Line alignment equipment lets you custom design an aligner system to best fit your facilities and your production requirements.

The Bee Line add-a-unit design safeguards your investment against obsolescence and is expandable to meet your needs. Each piece is engineered to assure safety and flexibility through a wide range of vehicles. The alignment machine can be used for truck frame correction by adding the Bee Line Frame Press.



CONFIGURATION OPTIONS

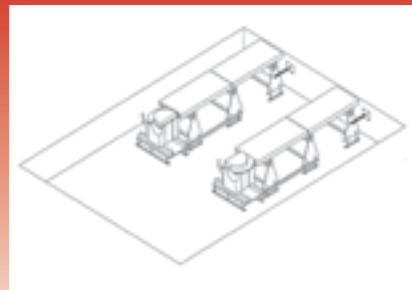

AA 2D2 - 2-Section pit machine (24" deep x 15' wide minimum x 17' 2" long minimum) (60.96 cm deep x 457.2 cm wide minimum x 523.24 cm long minimum)
Add 45" (114.3 cm) for each additional section.

Custom Design a Machine to Best Fit Your Facility

ELEVATED SOLUTIONS/CONFIGURATIONS



AR330C 24" Double Approach Ramps (Pair)
AR330D 30" Double Approach Ramps (Pair)
Fixed approach ramps are used with the Advanced Aligner Runways.

885.12D 24" Heavy Duty Dual Air Jack
Bee Line's Heavy Duty Air Jack provides safe and easy lifting on all Advanced Aligner Runways. Available in 24" or 30" height (878.12D). 3,500 lbs. capacity for every 25 lbs. of air line pressure.

29541 King Pin Turning Aligners (Pair)
Use with WindSpeed 7500 to electronically measure and display Ackerman Angle, turn radius, KPI and caster without pushing buttons or interpreting a scale. One person can do the alignment measurements, saving time and increasing profits in your shop.
Load Capacity: 32,000 lbs. per axle.

176 24" Support End Leg
Developed to prevent the runway top from deflecting when driving on and off the Turning Aligners. These legs are interchangeable and available in 24" or 30" height (178).

174 24" Runway Legs
Standard runway legs are interchangeable and can be used with any new or existing installation. Available in 24" or 30" height (175).

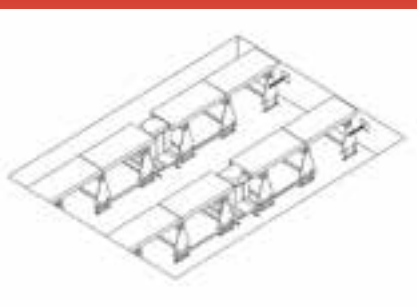

AA 4D4 - 4-Section drive thru wheel alignment (24" deep x 15' wide minimum x 17' 2" long) (60.96 cm deep x 457.2 cm wide minimum x 523.24 cm long)



AA 7D2 WITH AR 330C - 7-Section above ground wheel alignment machine with double approaches (43' 6" long x 24" high) (1325.88 cm long x 60.96 cm high)

Elevated Solutions/ Configurations



Space Saver Ramp Features:

The Space Saver Alignment System is totally above ground adding these great benefits:

- Save valuable space.
- Gradual incline.

Stationary Space Saver Ramp

Bee Line designed the Space Saver Ramp to be installed in a smaller area than a standard ramp alignment system by reducing the total number of machine sections required. The design of the Space Saver allows a major portion of the ramp to be raised hydraulically to an operating level equal to the height of the Advanced Aligner Runways.

The longer design of the Space Saver lifting ramp creates a more gradual incline, therefore requiring less runway sections.

Once the truck is in position, the Runways are hydraulically lifted with the touch of a button. The approach ramp incline angle allows low profile buses and RVs to drive on without bottoming out.

The Bee Line Space Saver Approach Ramp System is another example of how Bee Line continues to set the standard for wheel and frame alignment in the heavy-duty trucking industry.

Space Saver Ramp Specifications:

- Length of runway section: 45" x 19".
Optional 45" x 25"
- Length of Approach Ramp: 23 feet 4 inches

CONFIGURATION SPECIFICATIONS

- Lifting Length: 16 feet
- Ramp Height: 24 inches or 30 inches
- Lifting Capacity: 11 tons, hydraulically powered
- AR400 & AR401 models are used with 24 inch high Runway Sections. Incline angle: 4.5 Degrees
- AR400.30 & AR401.30 models are used with 30 inch high Runway Sections. Incline angle: 5.7 Degrees
- Can be configured in any number of sections.

Designed for the Shop Where Space is at a Premium



AR400 Space Saver Ramp
The design of the Space Saver allows a major portion of the ramp to be raised hydraulically to an operating level equal to the height of the Advanced Aligner Runways.
AR400 - 24"
AR400.30 - 30"

885.12D 24" Heavy Duty Dual Air Jack
Bee Line's Heavy Duty Air Jack provides safe and easy lifting on all Advanced Aligner Runways. Available in 24" or 30" height (878.12D). 3,500 lbs. capacity for every 25 lbs. of air line pressure.

29541 King Pin Turning Aligners (Pair)
Use with WindSpeed 7500 to electronically measure and display Ackerman Angle, turn radius, KPI and caster without pushing buttons or interpreting a scale. One person can do the alignment measurements, saving time and increasing profits in your shop.
Load Capacity: 32,000 lbs. per axle.

4 Ft. Removable Sections
Runway Legs are available in 24" and 30" high. The length of the runway section is 45" x 19" wide. Optional 45" x 25" section. Adjustable runway/tire width 45" to 100".
Load Capacity: 32,000 lbs. per axle.

900 Series Electric Hydraulic Pump
The pumps allow operation of rams together or separately. They operate on 115V, 10,000 PSI and require 30 amp service. (See page 45 for complete list of available styles)

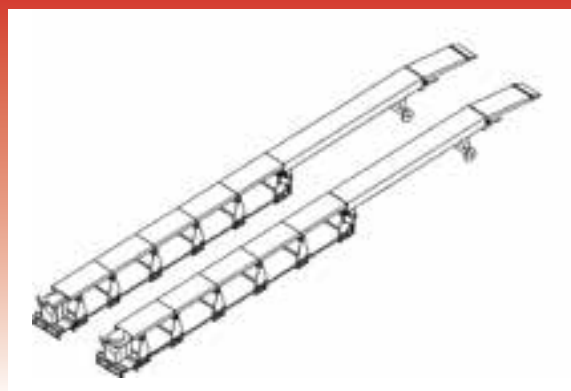

Elevated Solutions/ Configurations

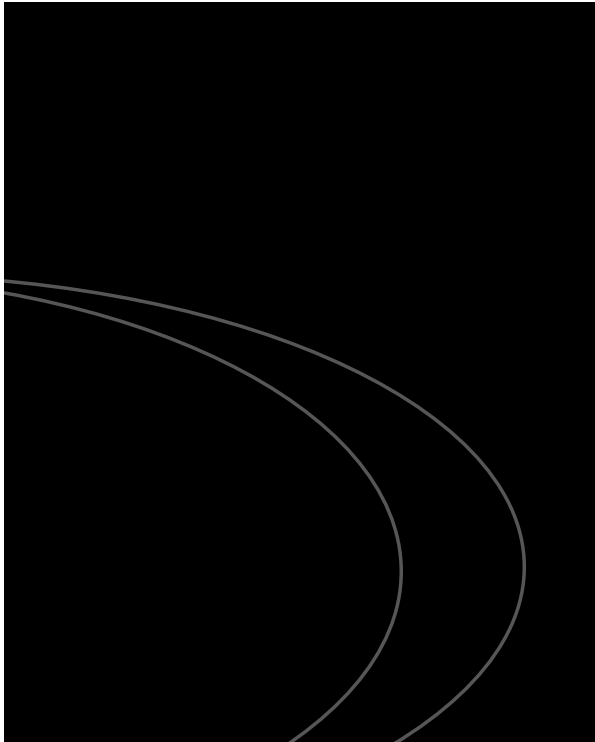

Stationary

Pit Models

Common Configurations are:

- "L" Pit Model
- "T" Style Center Pit Model
- Eight Section Step Down Model
- Four Section Drive Thru Pit Model
- Twelve Section Drive Thru Model

Key Features:

- Custom configurations to meet your shop's needs
- Ergonomic design optimized for alignment
- Multi-Purpose
- A walk-under center pit saves time spent raising and lowering a vehicle
- Choose between 24" or 30" Runway Legs

Specifications and site requirements vary. Please speak with a Bee Line Authorized Representative to maximize efficiency and optimize work space.



PIT CONFIGURATION OPTIONS



"L" Pit Model

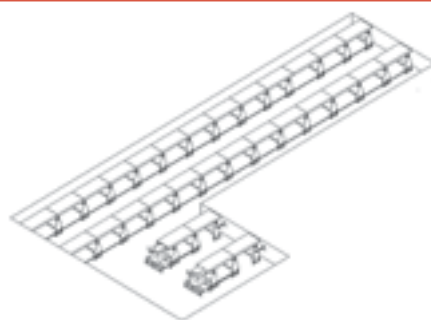

"T" Style Center Pit Model

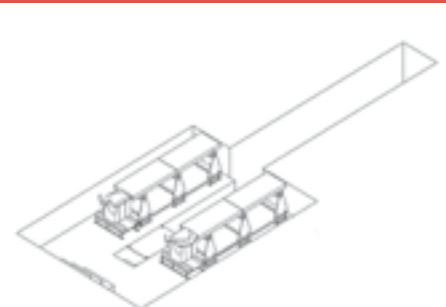

Turn Your Shop into a Profit Center

24" or 30" Runway Legs
Standard Runway Legs are available in 24" and 30" tall models, are interchangeable and can be used with any new or existing installation.



29541 King Pin Turning Aligners (Pair)

Use with WindSpeed 7500 to electronically measure and display Ackerman Angle, turn radius, KPI and caster without pushing buttons or interpreting a scale. One person can do the alignment measurements, saving time and increasing profits in your shop. Load Capacity: 32,000 lbs. per axle.



885.12D (24") Heavy-Duty Air Jack
Bee Line's Heavy-Duty Air Jacks provide safe and easy lifting on all Advanced Aligner Runways.

Eight Section Step Down Model

Four Section Drive Thru Pit Model

Twelve Section Drive Thru Model

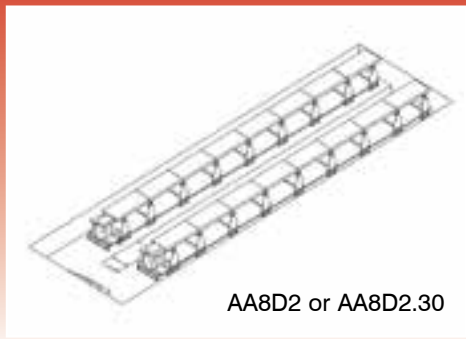

AA8D2 or AA8D2.30

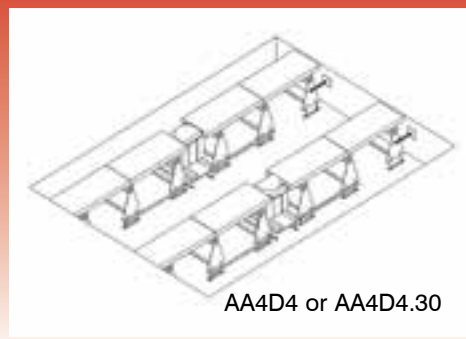

AA4D4 or AA4D4.30

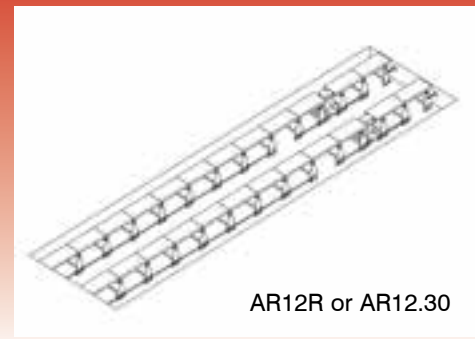

AR12R or AR12.30

Elevated Solutions/ Configurations

Four-Post Lift Features:

- Diamond plated ramps and runways
- Safety locking legs on each post
- Hydraulic velocity fuse backup safeties
- Front wheel stops
- Available as an optional open front beam type
- Optional alignment lift radius and slip plates
- Remote pendant control (25")

Stationary

Four-Post Lift, Scissor Lift & Mobile Column Lift



Quality Workmanship and more than 40 years experience, collectively in the Lift Industry, goes into every product. Being the leader in lift innovation and utilizing a wide range of the newest technologies in lift controls and hydraulic fluid power makes these products superior. A wide variety of lifts are manufactured for use in maintenance shops, including Heavy Duty 4-Post Drive on Lifts, Mobile Column Lifts and Scissor Lifts.

All products are tested under numerous temperature and structural stress conditions using Innovative Methods. These test systems lead to cost savings and enhanced superior quality.

Every Lift produced is built to the ANSI ALI-ALCTV-2011 Standard for Automotive Lifts Safety Requirements for Operation, Inspection and Maintenance. The majority of the lifts have been tested and certified to meet or exceed the ETL requirements for lift safety.

Elevated Solutions/ Configurations

Portable Aluminum Runways



402600.CTA
**Runway Section with Center
Cut-out for Turning Aligner**



402620 **Aluminum
Storage Cart**

402601 **Portable
Aluminum Ramps**



402600 **Portable
Aluminum Runway
Section**

29540P **Paired Portable
Turning Aligners**

Bee Line adds a new dimension to Portable alignments by designing aluminum runways that raise vehicles eight inches off shop floors. This extra clearance allows access under the vehicle when making alignment adjustments and also when performing general vehicle maintenance.

Bee Line designed this runway system with your shop's valuable time and floor space in mind. When runways are used with the Bee Line 7800 Floor Jack, all alignment measurements can be taken, including runout, toe, camber, caster, steering stops, toe-out on turns and KPI. Toe can easily be adjusted with the vehicle on the runways.

When used in conjunction with a frame press, after the the press raises the vehicle, runway sections can be removed and stacked to keep the vehicle elevated while frame adjustments are being performed. Cab corrections can also be made by utilizing the Bee Line Power Tower.

402600 Portable Runway Sections Specifications:

Weight per section: 52 pounds

Load Capacity: 5 tons per section

Runway Sections: 20" wide x 48" long x 8" tall

Aluminum Runway Features:

- Runway Sections can be assembled in a matter of minutes
- Sections securely stack on a portable cart that significantly helps speed set up and take down time
- Portable runways are ideal for use with Bee Line's Drive Over Frame Press

Elevated Solutions/ Configurations

Components & Accessories

These accessories can be valuable add-ons to your existing alignment systems. Contact your local Sales Representative or Bee Line to learn what accessories best suit your shop's needs.

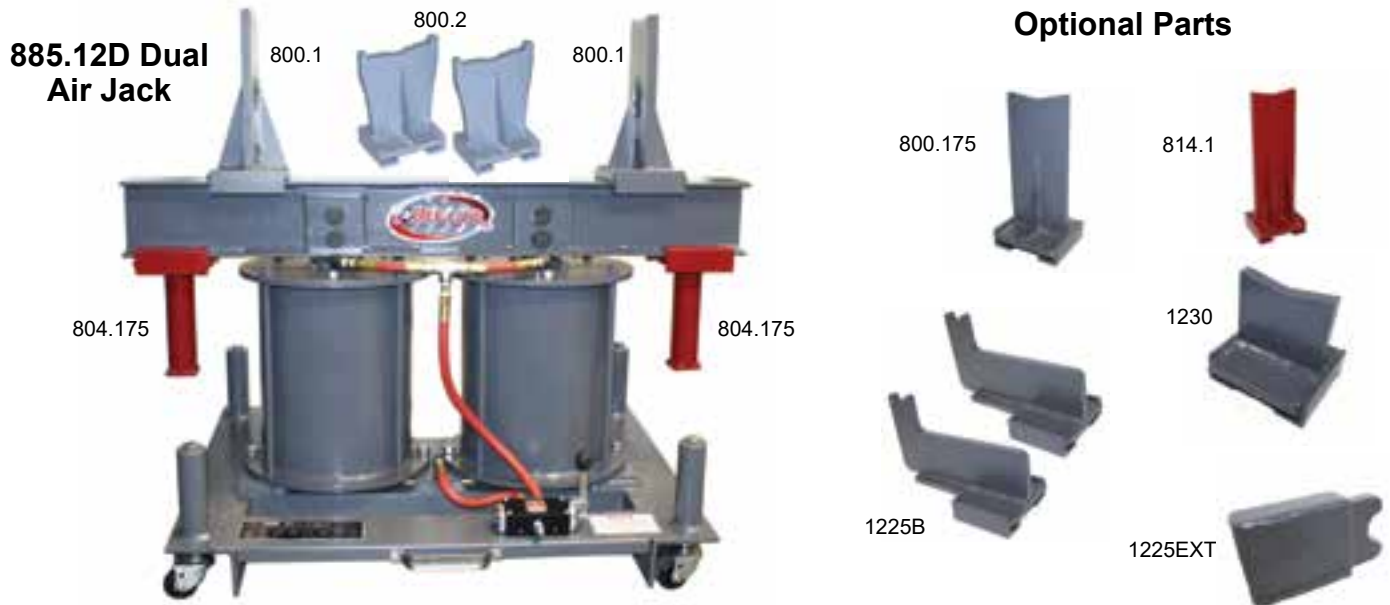

Heavy-Duty Air Jacks & Components

Bee Line's Heavy-Duty Air Jack provides safe and easy lifting on all Advanced Aligner Runways. Available in a dual model. The dual air jack (pictured) has a capacity of 3500 lbs. (1590.91 kg) for each 25 PSI (1.76 kg/cm²). 885.12D (dual) are 24" models and 878.12D (dual) are 30" models. Different base widths are also available. The following components can be utilized with the dual air jack.

Heavy-Duty Air Jacks and Components

Qty	24" Part No.	30" Part No.	Description	Capacity/25 PSI
1	885.12D	878.12D	Dual Air Jack	3500
1	885.12SPD	878.12SPD	Dual Air Jack - Wide Base	3500

Components That Come Standard

Qty	24" Part No.	30" Part No.	Description	Capacity/25 PSI
2	800.1	--	10" Axle Support	
2	800.2	--	Fabricated Axle Support	
2	804.175	--	7.5" Safety Stands	
2	1225B	--	6 5/8" Axle Support	
1	--	744.15	6" Riser	

Optional Components

Qty	24" Part No.	30" Part No.	Description	Capacity/25 PSI
2	800.175	--	7 1/2" Axle Support	
2	814.1	--	14 1/4" Extra Long Axle Support	
2	1230	--	4" Axle Support	
2	1225EXT	--	3" Extension Assembly	
	826.12SP	--	64" Extended Beam (Independent Suspension Adaptor)	

Components & Accessories



Part No. 18546 Removable Leg Step

This lightweight step locks into existing holes on Runway Legs and can easily be moved to the Leg where it is needed. Supports one person.



Part No. 29070 Runway Service Step

Step attaches between any two Runway Legs and allows easy access to Truck or Auto.



Part No. 29090 Turning Aligner Service Step

Step attaches to the side of 29540 King Pin Turning Aligners and allows easy access to Truck or Auto.



Part No. 29544 Toe Gauge Support

Supports provide a convenient resting place for Toe-In Gauges when performing manual alignments. **Not for standing.**



Part No. 29600 Runway Lift Assembly

Easy to operate lift makes moving removable sections a snap. The Runway Lift Assembly uses four caster wheels that allow for easy movement in any direction and does not require the use of electric, air or hydraulic power. The lift can be assembled onto any existing removable section in a matter of minutes and contains leveling and height adjustments to accommodate variations in installation heights.

Axle Correction Tools



Camber Correction

Bee Line has long been a proponent of the benefits of camber correction, which, as part of a total vehicle wheel alignment, allows vehicle owners to achieve maximum tire life and fuel efficiency from their vehicle. The following information is designed to help you understand the benefits of camber correction.

Camber Correction Innovation

Nearly all passenger cars and light trucks have adjustments for camber, or have aftermarket shim adjustments so camber can be changed and fine-tuned. It is known that adjusting the camber to preferred settings

increases tire life while improving vehicle handling. Conversely, most heavy duty trucks have straight axles that do not have similar accommodations for camber adjustment. As a result, the only way to change the camber is to correct set, or hydraulically adjust the axle.

This is where Bee Line technology has been utilized for more than 90 years. George L. Hunt, early inventor and automotive enthusiast, put Bee Line on the map by manufacturing the first axle correction equipment in the 1920s. Since then, Bee Line's mission has been to effectively manufacture cutting-edge wheel alignment equipment that helps solve irregular handling and tire wear conditions.

TOTAL SOLUTION

Our equipment and patented methodology represent the safest and most effective way to correct camber on truck axles.

Maximum Performance

Thousands of shops and trucking fleets that perform truck alignment, including camber correction, realize the only practical way to change camber is to correct set. They do this because they and the vehicle owners see firsthand the benefits of a proper camber setting in relation to tire wear, fuel efficiency and the overall operating costs of the vehicle.

Bee Line is confident that our equipment and patented methodology represent the safest and most effective way to correct camber on truck axles.

Owner Choice and Responsibility

It is also important to note that the camber setting recommended by the Truck Maintenance Council (TMC) is tighter than most axle manufacturer's original specifications, and Bee Line's preferred settings are even tighter than the TMC specs. Therefore, a lot of axles will be outside the TMC and Bee Line specs. That is why the TMC suggests that if camber specifications exceed those listed in the TMC manual, "consult the vehicle, axle, and/or alignment equipment manufacturer." Bee Line does not promote that camber is a warranty issue. Nearly all manufacturers leave the decision of correcting the camber to preferred settings up to the vehicle owner.

If the camber is within the axle or truck manufacturer's tolerances, but outside the TMC or Bee Line specs, it is the vehicle owner's responsibility to adjust their camber to the preferred settings. Bee Line has proven that our preferred camber settings make a significant difference in tire life, which is why truck owners across the country choose to reset their camber to meet Bee Line specifications.

Effects of Camber and Toe

There have been studies over the years on wheel alignment conditions and tire wear.

The chart at right summarizes the effect of camber on trucks in a controlled experiment over two years. This illustrates the outcome of having identical toe settings while varying camber setting vs. the average tire life for each group.

It was concluded that +1/4 Left Camber and -1/8 Right Camber was the optimal setting. Other settings varied as much as 27% from the optimal setting before the tires needed to be replaced. This study justified what Bee Line has known for decades. Camber is a vital characteristic in extending tire life and significantly lowering the vehicles operating costs.

If you would like to know more about Bee Line's proven alignment philosophy and our cutting edge technology featuring our camber correction tools, contact us today at 800-728-7828 or visit us online at www.beeline-co.com.

Camber Setting (in degrees)		Toe Setting (in inches)
Left	Right	+0.040 This is the Industry Standard Setting
-3/4	-1	157,000 Miles Average Tire Life 90% of Optimal Setting
-1/4	-1/2	155,000 Miles Average Tire Life 89% of Optimal Setting
+1/4	-1/8	175,000 Miles Optimal Camber and Toe Setting (100%)
+3/4	+1/2	137,000 Miles Average Tire Life 78% of Optimal Setting
+2	+1 3/4	127,000 Miles Average Tire Life 73% of Optimal Setting



Axle Correction Tools



Most passenger cars and light trucks have adjustments or aftermarket kits to adjust camber and caster to preferred specifications vs. OEM tolerances. It only makes sense to set a Heavy Duty Truck to preferred specifications also.

Floating beam systems allow the operator to fine-tune the axles to these preferred specifications.

Truck Axle Correction

Heavy duty over the road truck tires are normally more than 3 times the cost of passenger car tires and average 4 times the miles per year. This allows equipment payback in tire savings over a very short period of time.

Bee Line promotes preferred Bee Line Wheel Alignment Specifications vs. the OEM manufacturing tolerances, and now the Truck Maintenance Council (TMC) also recognizes the importance of setting to a preferred target specification. The patented Bee Line Floating Beam allows you to adjust the axle into these preferred specifications.

The Floating Beam can be mounted parallel or at an angle to the axle, allowing the operator to correct both camber and caster conditions. Specific tools were designed to be used safely with the beam. When used with the Bee Line AA Machine, one technician can correct heavy-duty truck axles on the vehicle.

Camber corrections are accomplished by using bridge hanger-type tie-downs to hold the axle in place while powerful Bee Line Hydraulic Rams (up to 125 tons) correct camber by pushing the axle upward.

Bee Line's exclusive axle correction equipment is a must for the Truck Repair facility that wants to perform Complete Truck Alignment Service.

Axle Correction Tools

Front Axle Tools

404 Tool Group - Light Axle Tools

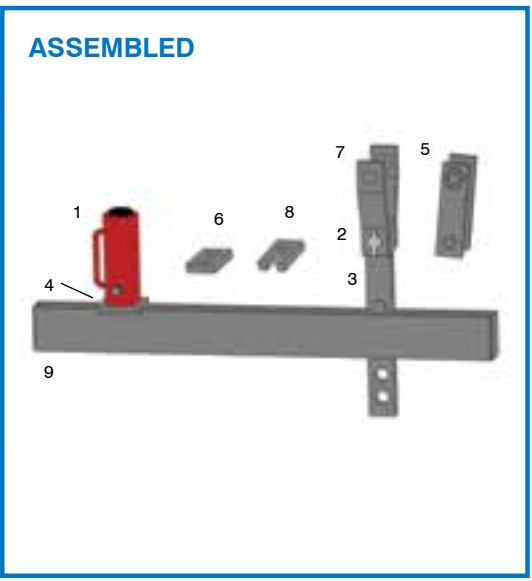
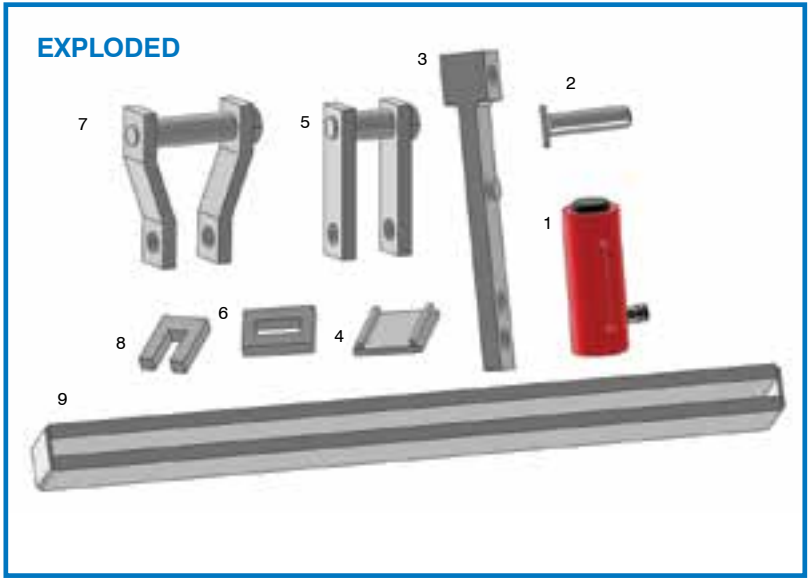

Number	Part Numbers		Description	Qty
	404	404AL		
1	FR30	FR30	30 Ton Ram	2
2	404067	404067	Pin Assembly 1 1/2" dia. X 6"	4
3	404116	404116	Connector	2
4	404102	404102	Jack Base	2
5	404105	404105	Narrow Clevis	2
6	404119	404119	Pin Adaptor Plate	2
7	404110	404110	Spring Pad Clevis	2
8	404120	404120	Spacer	2
9	404100SP	404100AL	Beam / Aluminum Beam	1

OPTIONAL ACCESSORIES

404150 Medium Duty Clevis



2-1416 Twisting Hook for Caster Correction - Not Shown
404151 Caster Correcting Yoke - Not Shown

404 TOOL CONFIGURATION



404 Equal Decrease



404 Equal Increase

Axle Correction Tools

Front Axle Tools

Tool Group 405BL - Heavy Duty Axle Tools

Number	Part Numbers	Description	Qty
1	15150A	Beam Lift	1
2	404005	Spacer	2
3	100AL	100 Ton Aluminum Ram	2
4	1638	Jack Pad Weld - 4 1/4-inch high	2
5	404030	Front Twisting Hook 5" Wide x 5 1/2" Deep	1
6	404052A	Rear Twisting Hook	1
7	404055	Connecting Link Weld (New Style)	1
8	1510A	3/8" x 1 3/4" x 5 Blocking	4
9	1512A	1" x 1 3/4" x 5 Blocking	2
10	1588	Jack Base	1
11	403003	Pins	2
12	1589	Block	2
13	609024	1 1/4" - 7 x 6" Cap Screws	2
14	620013	1 1/4" - 7 Hex Nuts	2
15	1590	Axle Twisting Yokes	2
16	404000	Axle Camber Beam 56" Weld	1
17	15015	Chain 5/16"	1
18	15000.15	Spring Lift	1
19	FR10	10 Ton Ram	1
20	100AL.3B	Transport Ring	2
21	404010A	Axle Clevis	2
22	404011A	Spring Pad Clevis	2
23	404012	Connector Weld	2
24	404016	Clevis Pin	4
25	404167	Middle Ram to Axle Spacer	4
26	404166S	Beam to Axle Spacer	2

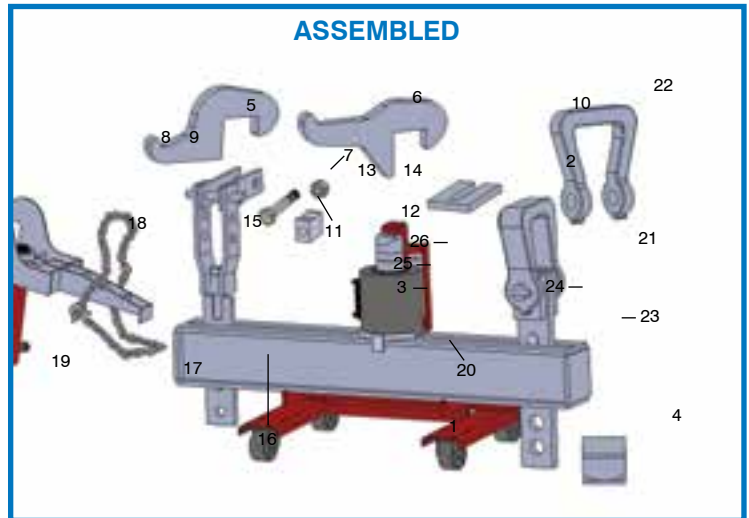
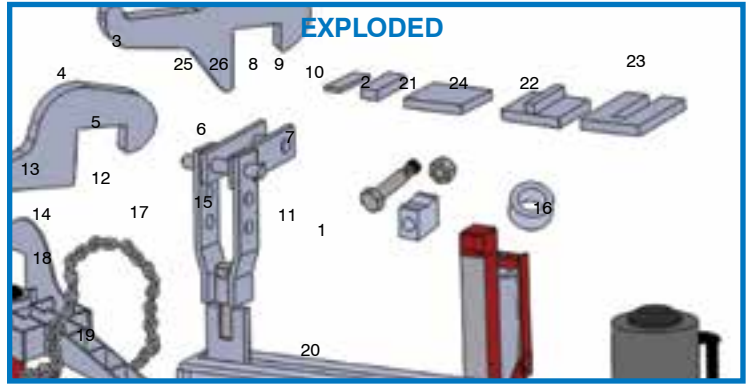

* See upgrade to this package on page 42, Tool Group 406U

405BL TOOL CONFIGURATION



405BL Equal Decrease



405BL Dissimilar

Axle Correction Tools

Front Axle Tools

Tool Groups 406HDL and 406L - Ultra Axle Tools 125 or 100 Ton Aluminum

Number	Part Numbers		Description	Qty
	406HDL	406L		
1	15150A	15150A	Beam Lift Assembly Omega Jack	1
2	404060	404060	Connector SD Weld	2
3	404067	404067	6 Inch Yoke Clevis Pin Weld	4
4	404065	404065	8 Inch Yoke Clevis Pin Weld	4
5	404063	404063	Narrow Clevis	2
6	404064	404064	Spring Clevis Pad	2
7	125AL	100AL	125 / 100 Ton Aluminum Ram	2
8	1638	1638	4 1/4" High Jack Pad Weld	2
9	404030	404030	Front Twisting Hook	1
10	404052A	404052A	Rear Twisting Hook	1
11	404055	404055	Connecting Link Weld (New Style)	1
12	1510A	1510A	Block, Spacer 3/8" x 1 - 3/4" x 5	4
13	1512A	1512A	Block, Spacer 1" x 1 - 3/4" x 5	2
14	1588	1588	Plate, Jack Base	1
15	403003	403003	Pin, Long 1 1/4 x 8 1/2	2
16	1589	1589	Block	2
17	609024	609024	1 1/4-7 x 6 HX HD GR5 Cap Screw	2
18	620013	620013	1 1/4-7 HX Nut	2
19	1590	1590	Axle Twisting Yoke Weld	2
20	404000	404000	Axle Camber Beam 56" Weld	1
21	15015	15015	5/16" Chain Assembly	1
22	15000.15	15000.15	Spring Lift	1
23	FR10	FR10	10 Ton Ram 6 1/8" Stroke	1
24	403098	403098	Spacer	2
25	125AL.3B	100AL.3B	125 / 100T Transport Ring Assembly	2
26	404005	404005	Spacer	2
27	404166S	403098	Middle Ram to Axle Spacer	4
28	404167	403098	Beam to Axle Spacer	2

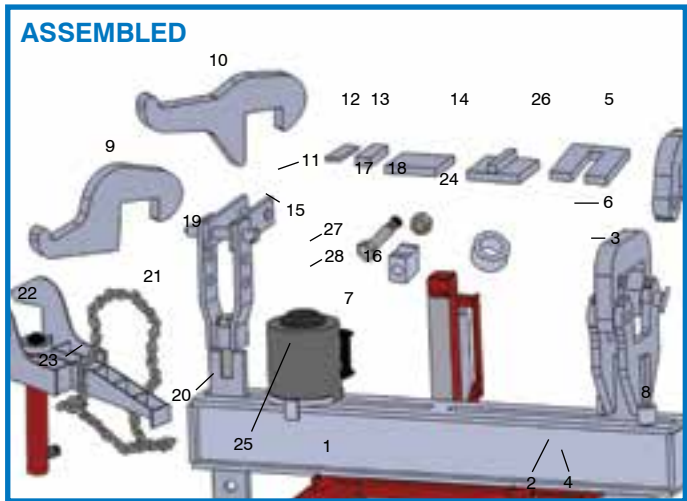
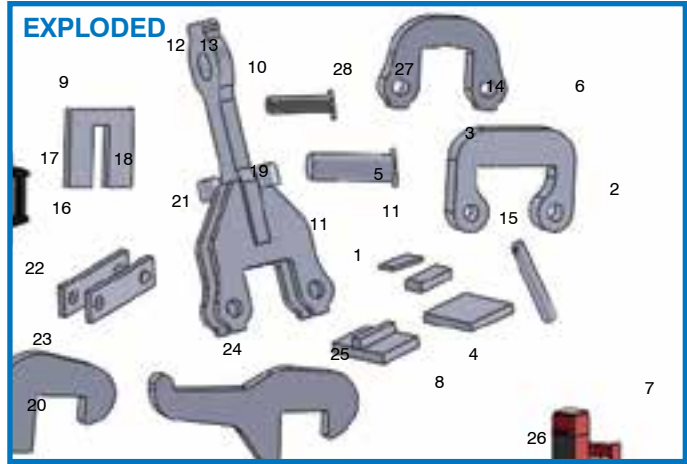

406 HDL TOOL CONFIGURATION



406 Equal Decrease



406 Equal Increase

Axle Correction Tools

Front Axle Tools

Tool Group 406U - Heavy Duty Axle Tools Upgrade

Part Numbers			
Number	406U	Description	Qty
1	404060	Connector SD Weld	2
2	404067	6 Inch Yoke Clevis Pin Weld	4
3	404065	8 Inch Yoke Clevis Pin Weld	2
4	404063	Narrow Clevis	2
5	404064	Spring Clevis Pad	2

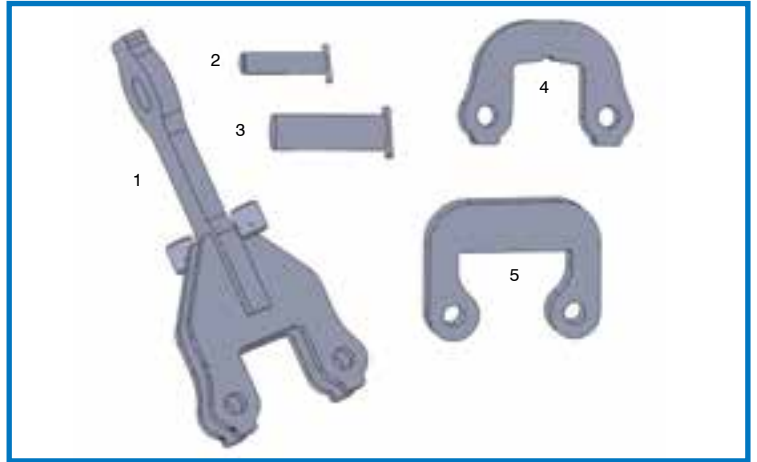

* Upgrade to Tool Group 405BL on page 40

Part No. 404075 Confined Area Clevis

This clevis is an essential heavy duty axle clevis that expands the functionality of our proven 406 Axle Tools. The new 404075 Confined Area Clevis is designed to slip around the axle on the outside of the spring seat on most trucks with 16,000 pounds or greater axles. The universal design eliminates the removal of the tie rod and in most cases the drag link when making a positive camber correction.



Tool Group 407U - Tools Upgrade

Part Numbers			
Number	407U	Description	Qty
1	404180	Saddle	2
2	404163	Axle Connector	2
3	404170PP	36" High Capacity Axle Strap	1
4	404170C	Boot	2
5	404170.40PP	40" High Capacity Axle Strap	2
6	404065	8" Yoke Clevis Pin Weld	2
7	404165	1/2" Spacer Beam to Conn	4
8	404165A	1/4" Spacer Beam to Conn	2
9	404172	Adaptor Cap	2
10	404168	Aluminum Ram Spacer Head	2
11	404167	Middle Ram to Axle Spacer	4
12	404166S	Ram to Axle Spacer	2
13	403706	Stackable Fab Axle Push Block	2
14	404168A	125T Aluminum Ram Spacer HD	2
15	610016	1/4-20 x 3/4 Bolt	8*
16	610014	1/4-20 x 1/2 Bolt	4*

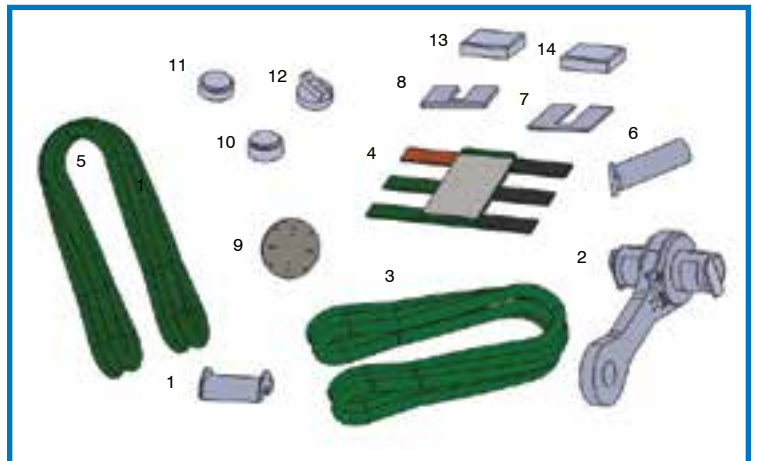

*Not pictured

Axle Correction Tools

Front Axle Tools

AXLE CORRECTION TOOLS

Tool Groups 407CU and 407HU - Heavy Duty Axle Tools

Number	Part Numbers		Description	Qty
	407CU	407HU		
1	15150A	15150A	Beam Lift Assembly Omega Jack	1
2	404005	404005	Spacer	2
3	404065	404065	8" Yoke Clevis Pin Weld	2
4	100AL	125AL	100 / 125 Ton Aluminum Ram Ass'y	2
5	404000	404000	Axle Camber Beam 56" Weld	1
6	15015	15015	5/16" Chain Assembly	1
7	15000.15	15000.15	Spring Lift	1
8	FR10	FR10	10 Ton Ram	1
9	100AL.3B	125AL.3B	Transport Ring 100AL / 125AL Weld	2
10	404163	404163	Axle Connector	2
11	404165	404165	1/2" Spacer Beam to Conn	4
12	404165A	404165A	1/4" Spacer Beam to Conn	2
13	404166S	404166S	Ram to Axle Spacer	2
14	404167	404167	Middle Ram to Axle Spacer	4
15	404168	404168A	Aluminum Ram Spacer Head	2
16	403705	403705	60 Ton Push Block	2
17	404180	404180	Saddle	2
18	404055	404055	Connecting Link Weld	1
19	404170PP	404170PP	36" High Capacity Axle Strap	1
20	404170.40PP	404170.40PP	40" High Capacity Axle Strap	2
21	404170C	404170C	Boot	2
22	1589	1589	Block	2
23	1590	1590	Axle Twisting Yoke Weld	2
24	609024	609024	1 1/4-7 x 6 HX HD GR5 Black	2
25	620013	620013	1 1/4-7 HX NT Zinc	2
26	404052A	404052A	Rear Twisting Hook	1
27	404030	404030	Front Twisting Hook	1
28	403003	4403003	Pin, Long 1 1/4 x 8 1/2	2
29	1510A	--	Block, Spacer 3/8" x 1 3/4" x 5"	4
30	1512A	--	Block, Spacer 1" x 1 3/4" x 5"	2

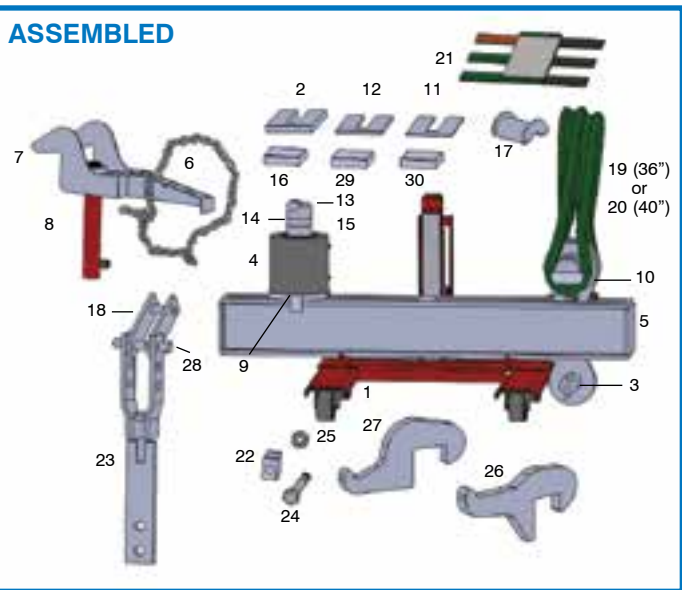
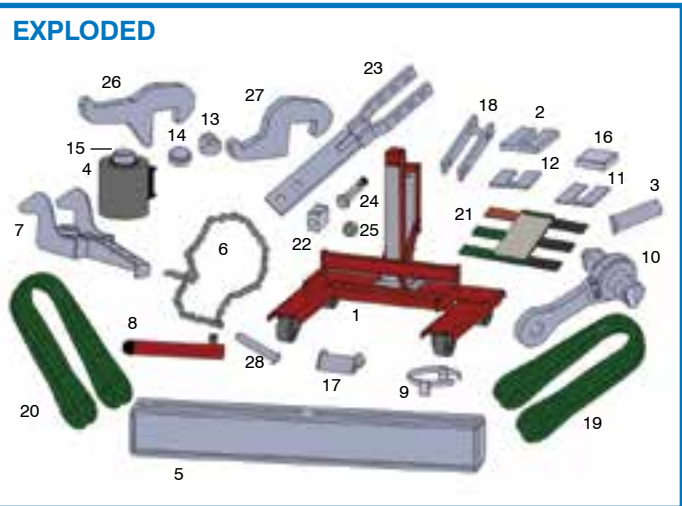

407 TOOL CONFIGURATION



407 Equal Decrease



407 Equal Increase

Axle Correction Tools

Rear Axle Tools

Tool Group 6 - Rear Housing Tools

EXPLODED

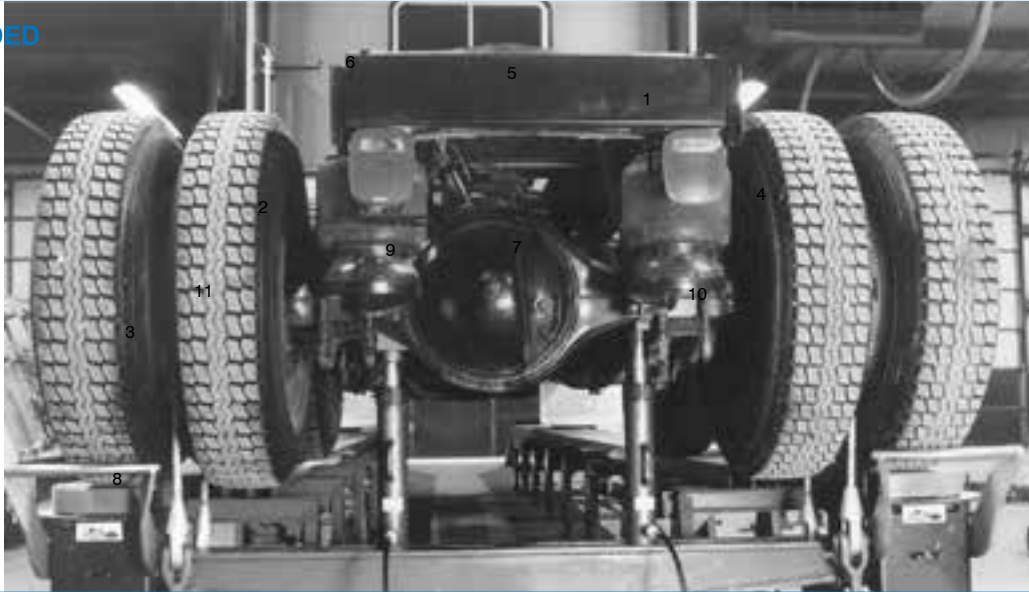

Part Numbers

Number	Tool Group 6	Description	Qty
1	1607	Extensions	4
2	1122	Short Pins	6
3	1650	84" Beam	1
4	1624	Cable Slings	2
5	1638	Jack Pad Weld - 4 1/4-inch high	1
6	1639	Jack Stand 7"	1
7	1638A	Housing Cradle	1
8	1614	Cables	2
9	1630	Beam Support	2
10	1670	Housing Cradle Adaptor	1
11	1675	Ram Holder	2

ASSEMBLED

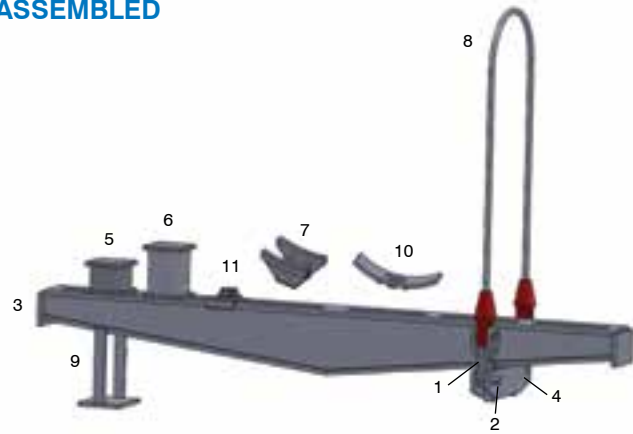

Pumps & Rams

Bee Line Ram Accessories

Get Power Where You Need It...



Pumps come with 875 PSI gauge.

875 PSI Gauge (Standard)

The Bee Line PSI Gauge allows you to know how much pressure you are applying continuously. This gauge plugs directly into the coupler on the pump. With the Bee Line PSI Gauge you will never need to guess again if your pump is working correctly.



900 Series Electric Hydraulic Pump

The Bee Line Electric Hydraulic Pumps are the finest pumps available on the market. The pumps allow operation of rams together or separately. They operate on 115V and require 30 amp service.

The two stage system has a high volume first stage for output below 300 PSI. It automatically switches to a 10,000 PSI second stage for efficient work.

Listed below are the specifications on the models available from Bee Line.

- 900B** Four valve pump for frame applications
- 900E** Two valve pump for alignment applications
- 900C** Four valve pump with solenoid operated valve
- 900D** Two valve pump with solenoid operated valve

Optional: Stand for 900 Series Pumps

PN 899 Optional 3-shelf metal stand features durable, powder coated roll formed shelves, a weight capacity of 300 lbs. of evenly distributed weight and an arc-welded construction to stand up to years of heavy use. The cart is height adjustable in 2" increments from 24" to 42" high. 4" casters (two with brakes) enable ease of mobility.

Model 7500

This pump operates on air pressure and allows operation of two hydraulic rams individually or together with maximum output of 10,000 psi. The Model 7500 is designed to be foot or hand operated and is equipped with a two gallon reservoir.



Overall Dimensions:

- Length: 24"
- Width: 18"
- Height: Adjustable from 24" to 42"
- Capacity: 300 lbs.

Pumps & Rams

Bee Line Ram
Accessories

Bee Line Ram Accessories



Bee Line Ram Specifications (All Rams rated at 10,000psi)

Number	Model	Description	Tons Capacity	Closed Height	RAM Travel	Extended Height	RAM Diameter	RAM Retraction	Wt. (lbs.)	Repair Kit	Repair Kit Option
1	FR10	Standard 10 Ton Ram w/HD Couplers	10	11 3/4"	6"	17 3/4"	2 1/4"	Spring	11	HW80807	RPA82093
2	FR10.5	Short 10 Ton Ram w/HD Couplers	10	4 1/2"	2 1/2"	7"	2 1/4"	Hand	5	HW80808	RPA82093
3	FR10.16	Long 10 Ton Ram w/HD Couplers	10	15 3/4"	10"	25 3/4"	2 1/4"	Spring	15	HW80807	RPA82093
4	FR20	Standard 20 Ton Ram w/HD Couplers	25	11 1/2"	5"	16 1/2"	3 1/2"	Spring	23	HW80809	FR20SEAL
5	FR20.19	Long 20 Ton Ram w/HD Couplers	25	19 1/2"	13"	32 1/2"	3 1/2"	Spring	40	HW80809	ERC2510K
6	FR30.5	Short 30 Ton Ram w/HD Couplers	30	4 3/4"	2 1/4"	7"	4"	Hand	14	HW81067	--
7	FR60	60 Ton Ram w/HD Couplers	60	11"	6"	17"	5 1/2"	Spring	57	HW80812	--
8	402230	20 Ton Telescoping Ram w/HD Couplers	20	10 1/2"	13"	23 1/2"	4 1/2"	Hand	43	402240	--
9	100AL	100 Ton Aluminum Ram (not shown)	100	10"	4"	14"	8"	Spring	40	100AL.17	--
9A	125AL	125 Ton Aluminum Ram	125	11.25	4"	15.25	9"	Spring	62	125AL.17	--
10	109170	Short 10 Ton Pull Ram	10	21"	11"	32"	2 1/2"	Air	31	109149	--
11	109140	X-long 10 Ton Pull Ram w/o Valves	10	30 1/2"	21"	51 1/2"	2 1/2"	Air	40	109149	--
12	109200	20 Ton Ram	20	27"	13 1/2"	40 1/2"	3 1/4"	Air	30	109210	--
13	FR30	Long 30 Ton Ram w/HD Couplers	30	10 1/2"	6"	16 1/2"	4"	Spring	3	HW8081000	--
14	402500.1	Short 20 Ton Ram	20	2 7/8"	1 1/4"	4 1/8"	4"	Hand	5	BLE20T1A	--
15	12569	Valve Assembly	--	--	--	--	--	--	--	--	--
16	845	15' Hose	--	--	--	--	--	--	--	--	--
17	845.30	30' Hose	--	--	--	--	--	--	--	--	--

Bee Line Ram Accessories

109000 10 Ton Ram Extension Kit

Number	Part Number	Description
14	109024	24" Extension Tube
15	109018	18" Extension Tube
16	109012	12" Extension Tube
17	109006	6" Extension Tube
18	109001	Tube Connectors (3)
19	109004	Ram Connectors (2)
20	109007	Tube Cap
21	A1035	Concave 90 Degree Head
22	Z129	Wedge Head
23	A1058	Flat Head

Optional - Not Shown - 1034 10 Ton Ram Base



403200 20 Ton Ram Extension Kit

Number	Part Number	Description
24	403206	6" Extension Tube
25	403209	9" Extension Tube
26	403212	12" Extension Tube
27	403218	18" Extension Tube
28	403224	24" Extension Tube
29	403236	36" Extension Tube
30	403210	Tube Connectors (3)
31	403205	Ram Spade
32	403202	Extension Cap
33	403208	Extension Spade
34	403204	Ram Connectors (2)

Optional - Not Shown - 403235 68" Extension Tube & 1037 20 Ton Ram Base



90 Years of Frame Correction Experience



Frame Correction Products Include:

- Standard Truck Frame Press: Works in conjunction with A.A. Runways.
- "I" Beam Systems that are constructed using in-floor I-beams.
- Drive Over Frame Press: Completely portable press that saves shop space.
- Dump Body Tools: Reshape damaged dump bodies.

Frame Correction and Press System

The Bee Line Truck Frame Machine and Press system is a chassis and suspension correction system for heavy-duty vehicles of all types. Considered to be the most accurate and efficient chassis and total suspension correction system available today, Bee Line leads the Truck Frame Correction Industry with its vast experience in equipment manufacturing, safety, training, backup service and profit potential.



With frame correction capabilities in your own shop, you no longer have to rely on outside sources to work the job into their schedule. You can perform the job quickly and cost effectively with reduced down-time.

Built tough and versatile to handle all makes of heavy trucks and equipment

The Bee Line extra heavy duty frame machine is designed to fit into your shop and to help increase your production and correct all chassis to better than new. The runways easily adjust from 39" to 94" tread width. The Bee Line frame machine has the ability to handle all sizes of trucks, buses, trailers and even specialized equipment. Bee Line's design makes corrections without causing additional damage to the vehicle and without heat. The vehicle retains its original tensile strength.

The Bee Line frame straightening system allows the operator full control over every part of the truck frame straightening operation.

FRAME CORRECTION OPTIONS



Frame gauging and equipment set up is done at a convenient height. Runways can be removed to allow easy access.

The Most Accurate and Efficient Chassis and Suspension System Available

Frame Tools

The Bee Line tool selection is versatile, providing the operator the safest hook ups with minimal disassembly of the damaged vehicle. These tool hook ups produce direct pressure in exactly the right location of the damaged frame.

Removable runways simplify locating the damage and positioning the proper tools.

The backbone of the machine is the frame press to which all tie downs, holds, pushes and pulls are connected.

Frame Press available in 3 lengths:

- 28 foot - Accommodates tractors only
 - Drive-on - 402260C
 - Drive-over - 402428
- 36 foot - Accommodates tractors, most trailers and buses
 - Drive-on - 402210C
 - Drive-over - 402436
- 40 foot - Accommodates all tractors, trailers and buses
 - Drive-on - 402270C



Our Frame Press hydraulically raises to bring the correction tooling to the truck. Runway sections are removed to allow easy access at a comfortable working height.



This diamond correction set up utilizes the force of a pull ram to bring the frame rails even with each other.



This twisted trailer is being corrected with our Trailer Twisting tools. Our Floor "I" Beam set up works primarily with trailer corrections. Also can be ordered for frame press.

Tools for Accuracy and Precision

Shop Equipment

4088 Bee Line's Smart Balancer II

What is On-the-Vehicle Balancing?

On-the-vehicle balancing refers to the Truck Maintenance Council's official recommended practice of truck wheel balancing. On-the-vehicle means the wheel is never removed from the truck during the balancing procedure. By leaving the wheel on, a technician not only balances the tire, he balances the hub and the drum in relationship to the truck's suspension. Balancing the entire wheel assembly provides a far more accurate "smart" balance.



1. A spinner brings the wheel up to speed.



2. A sensor measures wheel vibration



3. The touch screen indicates the position and how much weight should be placed on the wheel.

Why Do You Want the Smart Balancer II?

The new Smart Balancer II is easily the most user friendly on-the-vehicle balancer on the market today. The Smart Balancer II is the latest generation of touch screen computerized system that replaces all old strobe type balancer. This balancer is accurate and simple to use. From initial set up through the completion of the balance, the technician is prompted by simple step-by-step instructions. The Smart Balancer II balances wheels extremely fast by taking the guesswork out of placing weights on the tire. In a few short spins the touch screen illustrates the exact amount of weight and the exact position that weight should be added to the wheel. This process removes the chance for error and dramatically decreases the time it takes to balance each wheel.

In addition, the Smart Balancer II features customized workflow, increased accuracy and a new rugged design. With the Smart Balancer II, you make more money with a better quality balance in less time.



Extra Retroreflective tape rolls - PN 3107A



Tools for Accuracy and Precision

Shop Equipment

King Pin Gauge EPM718

Bee Line software technology affords the measurement, recording and the ability to print the results of a computer-driven king pin inspection. This one-of-a-kind software was developed to electronically record the movement in king pin bushings to determine if replacement is needed. KPGS readings are accurate, extremely repeatable and available in a customizable hard copy printout through WindSpeed 7000 or WindSpeed 7500.

Increase buyer confidence and add credibility to results with computer measured tolerance variance. Steering knuckle vertical and lateral end play industry standards have been set by TMC and Axle manufacturers to ensure safety. The King Pin Gauging System accurately records these measurements and indicates when a king pin is in or out of tolerance by these standards.

Bee Line's King Pin Gauging System can be quickly and easily installed, allowing you to better serve your customers. What was once a two man job can now be done by one. The results are available instantly and can be handed to a waiting customer or electronically sent to someone off-site.



7700 Floor Jack*

Why Work Twice as Hard?

Lift the whole front end or rear end in one go, not ONE corner at a time. Scorpion Jack lifts on the axle or on the frame. Your end lift (Bumper Jack) can't do that. Ideal for all heavy-duty truck and bus repair shops. Perform service on wheels and tires, brakes, suspension, alignment and much more.

- 24,000 lb. capacity
- Easy to use control handle extends to nine feet
- Air/hydraulic design so no pumping required
- Detachable pendant remote
- Lifts over 20" with a built-in safety lock
- Vertical handles provide comfortable working position that eliminates back pain
- At 8.25" tall it glides easily on floating casters under the lowest truck axles and the deepest rear ends
- Includes a selection of three saddles: low/medium/high

*Optional Accessory - Part No. 7710 Pair of Trailer Adapters.



4010 Tire Runout Gauge

Helps Lengthen Tire Life

The 4010 Tire Runout Gauge is a rugged and sturdy tool that can easily and quickly diagnose irregular wear and potentially dangerous runout in a given tire.

- Eliminate vibration and irregular tire wear issues.
- Properly match the high and low spots of tire and rim runout.
- Radial and lateral tests to show abnormal peaks, bulges, troughs or flat spots; deviation in roundness or a tire's sidewall plane
- The gauge is read by counting the lines separating the sliders and measures 0.01" runout.



Model 4000 Porta-Truer

Versatile Design for Absolute Accuracy

Fast, accurate and dependable, the heavy duty 4000 Porta-Truer is designed to roll up to any vehicle and true the tire without removing the wheel. The versatile design means the entire job can be completed within a matter of minutes. Truing the tire on wheel bearings ensures absolute accuracy.

- Self-sharpening blade with manual override and safety blade guard
- Versatile, low maintenance design
- Folding handle design for compact storage
- Built-in tire profile follower
- Cuts up to 17.5" wide on a 24" profile
- Adjustable work light
- 14 foot power cord
- Designed to handle bus, truck, trailer, car, light truck and racing tire applications
- Cutter and drive motor are 60Hz., 110-115 V, single phase. Shipping weight is 379 lbs
- Porta-Truer stand is optional
- Includes Scooter Seat with wheel weight tray



Hands-on Training Opportunities

Bee Line Training Courses

Bee Line Company offers training courses focused on the principles and techniques of performing computerized wheel alignment and truck frame correction. These courses have been developed to advance a beginning technician's skills to the next level. A fully equipped training center located near Bee Line's manufacturing facility in Bettendorf, IA provides the ultimate learning environment. Enroll in Bee Line's training courses and take your first step toward advancement. With more than 90 years of experience in wheel alignment and frame correction, you can trust Bee Line to help you succeed.

Log on to www.beeline-co.com or call Bee Line Customer Service to register. 800-728-7828 or 563-332-4066.

Bee Line Alignment Course

5 DAY COURSE:

8 Hours Classroom

32 Hours Hands-On Training

This training course is designed to teach the principles of alignment theory, vehicle (suspension system) inspection and equipment operation to an individual with one year or less service technician experience as well as an experienced alignment technician who wants to refresh their skills and knowledge. The course is a combination of classroom instruction and hands-on training that will provide an overview of suspension and steering systems with detailed instruction in performing proper inspection procedures.

Learning Objective:

The participant who completes this course will be able to:

- Describe the effects that improper wheel alignment will have on tire wear and vehicle handling.
- Recognize the factors that have the largest impact on alignment, including camber, caster, toe and tracking.
- Operate computerized alignment systems to perform measurements.



Bee Line Frame Correction Course

4 DAY COURSE:

4 Hours Classroom

28 Hours Hands-On Training

This training course is designed to teach the principles of truck frame correction. Participants will learn to diagnose, set up and correct common frame misalignment conditions in heavy duty trucks and trailers. Designed for an individual with one year or less correction technician experience as well as an experienced technician who wants to refresh their skills and knowledge. The course is a combination of classroom instruction and hands-on training. When taken in conjunction with the Bee Line Alignment course, the participant will learn to apply all the principles of Total Suspension Alignment.

Learning Objective:

The participant who completes this course will be able to:

- Recognize the factors that have the largest impact on alignment.
- Diagnose and set up misalignment corrections, including side-sway, twist, sag and diamond conditions.
- Operate Bee Line Advanced Aligner Machine to perform measurements and corrections.



Index by Part Number

Part #	Description	Page #	Part #	Description	Page #	Part #	Description	Page #
100AL	Aluminum Ram - 100 Ton	40	402600TA	Aluminum Runway	23	609024	7x6-inch Cap Screws - 1 1/4-inch	40, 41, 43
100AL	Aluminum Ram - 100 Ton	41, 43	402600TA	Portable Aluminum Runway Section	23, 33	620013	7 Hex Nuts - 1 1/4-inch	40, 41, 43
100AL.3B	Transport Ring - 100 Ton	40, 41, 43	402600	Portable Aluminum Runway Section - w/ cut-out	23, 33	744.15	Extended Beam 64"	34
109000	10 Ton Ram Extension Kit	47	402601	Portable Aluminum Ramp	23, 33	7500	Pump, Foot or Hand Operated, 2 Gallon Reservoir	45
1122	Short Pins	44	402620	Aluminum Storage Cart	33	7700	Floor Jack	17, 23, 25, 51
1225B	Axle Support - 6 5/8-inch	34	403003	Pin, Long - 1 1/4-inch x 8 1/2-inch	40, 41	7710	Trailer Extensions for Floor Jack (pair)	17
1225EXT	Extension Assembly - 3-inch (optional)	34	403098	Spacer	41	780	Supply Hose - 15 ft.	34
1225EXT	Extensions - 3 inch	34	403200	20 Ton Ram Extension Kit	47	782	Hose Quick Disconnect	34
1230	Axle Support - 4-inch (optional)	34	403705	Push Block - 60 Ton	43	800.1	Axle Support - 10 inch	34
125AL	Aluminum Ram - 125 Ton	41, 43	403706	Stackable Fab Axle Push Block	42	800.2	Axle Support - Fabricated	34
125AL.3B	Transport Ring - 125 Ton	41, 43	404000	Axle Camber Beam - 56-inch Weld	40, 41, 43	804.175	Safety Stands - 7 1/2 inch	34
1416	Twisting Hook for Caster Correction (optional)	39	404005	Axle Clevis	40	814.1	Extra Long Axle Support - 14 1/4-inch (optional)	34
15000.15	Spring Lift	40, 41, 43	404010A	Spacer	40, 41, 43	826.12S	Riser 6"	34
15000	Spring Lift with Chain	16	404016	Axle Clevis Pins	40	875	PSI Gauge - Standard	45
15015	Chain - 5/16-inch	40, 41, 43	404012	Connector Weld	40	878.12D	Heavy Duty Dual Air Jack - 30-inch	34
1510A	Block, Spacer - 3/8-inch x 1 3/4-inch x 5-inch	40, 41, 43	404011A	Spring Pad Clevis	40	885.12D	Heavy Duty Dual Air Jack - 24-inch	27, 31, 34
1512A	Block, Spacer - 1-inch x 1 3/4-inch x 5-inch	40, 41, 43	404030	Front Twisting Hook 5" wide x 5 1/2" deep	40, 41, 43	899	Stand	29, 45
15150A	Beam Lift Assembly Omega Jack	41, 43	404055	Connecting Link Weld (new style)	41, 43	900B	Pump, 4 Valve - Frame Applications	45
1585	Jack Tops	40, 41	404055	Extension	40	900C	Pump, 4 Valve - Solenoid Operated Valve	45
1588	Jack Base, Plate	40, 41	404052A	Rear Twisting Hook	40, 41, 43	900D	Pump, 2 Valve - Solenoid Operated Valve	45
1589	Block	40, 41, 43	404060	Connector SD Weld	41, 42	900E	Pump, 2 Valve - Alignment Applications	45
1590	Axle Twisting Yokes	40, 41, 43	404063	Narrow Clevis	41, 42	900	Electric Hydraulic Pump	29, 45
1607	Extensions	44	404067	Pin Assembly - 1 1/2-inch diameter x 6-inch	39	AR330D	Double Approach Ramps - 24-inch	27
1614	Cables	44	404064	Spring Clevis Pad	41, 42	AR400	Space Saver Ramp - 24-inch Runway Section	28, 29
1624	Cable Slings	44	404067	Yoke Clevis Pin Weld - 6-inch	41, 42	AR400.30	Space Saver Ramp - 30-inch Runway Section	28
1630	Beam Support	44	404065	Yoke Clevis Pin Weld - 8-inch	41, 42, 43	EPE261W	Wall Charging Station	17
1638A	Housing Cradle	44	404075	Confined Area Clevis	42	EPM715	Tread Depth Gauge	16
1638	Jack Pad Weld - 4 1/4-inch high	40, 41, 44	404100SP	Beam	39	EPM718	King Pin Gauge	51
1639	Jack Stand - 7-inch	44	404100AL	Beam - Aluminum	39	EPM720	Remote Display	17, 25
1650	Beam - 84-inch	44	404102	Jack Base	39	EPM940	Electronic Target	20
1670	Housing Cradle Adaptor	44	404105	Narrow Clevis	39	FJ7700	Floor Jack	17, 23, 25, 51
1675	Ram Holder	44	404116	Connector	39	FPT7860	Rear Slip Plates	15
174	Runway Legs - 24-inch	27, 31	404119	Pin Adaptor Plate	39	FPT8000	Portable Turn Plate - Aluminum	15
175	Runway Legs - 30-inch	31	404110	Spring Pad Clevis	39	FPT8500	Portable Turn Plate - Steel	15, 23, 25
176	Support End Leg - 24-inch	27	404120	Spacer	39	FPT9500	Portable Turn Plate - Heavy Duty	15
1790	Tire Scribe Gauge	14	404150	Clevis - Medium Duty (optional)	39	FR10	Ram - 10 Ton, 6 1/8-inch Stroke	40, 41, 43, 46
18305	Caster-Camber Gauge - Cars	14	404151	Caster Correcting Yoke (optional)	39	FR10.16	Ram, Long with HD Couplers - 10 Ton	46
18334	Calibration Bar - Mechanical Gauges	14	404163	Axle Connector	43	FR10.5	Ram, Short with HD Couplers - 10 Ton	46
18410E	Electronic Tram Gauge	20	404165	Spacer Beam to Conn - 1/2-inch	43	FR20.19	Ram, Long with HD Couplers - 20 Ton	46
18410A	Manual Tram Gauge	20	404165A	Spacer Beam to Conn - 1/4-inch	43	FR20	Ram, Standard with HD Couplers - 20 Ton	46
18546	Step - Removable Leg	35	404166S	Spacer - Ram to Axle	43	FR30	Ram - 30 Ton	39
19020A	Seat Gauge - Digital Spring	16	404167	Spacer - Middle Ram to Axle	43	LC4101.1	Wheel Mount - Cam Advancer	15
19020	Seat Gauge - Spring	16	404168	100T Aluminum Ram Spacer Head	42, 43	LC4102.1	Wheel Mount - Self-Centering	16
19290	Dolly Aligner Target	21	404168A	125T Aluminum Ram Spacer Head	42, 43	LC4195B.1	Wheel Mount - Center Mount	16
19305	Caster-Camber Gauge - Trucks	14	404170C	Boot	42, 43	LC7060	Portable Case	17, 23
19356	Spindle Gauges - Car	17	404170PP	High Capacity Axle Strap - 36"	42, 43	LC7500	Laser Guided Computer Wheel Alignment System	10
19358	Spindle Gauges - Truck	17	404170.40PP	High Capacity Axle Strap - 40"	42, 43	LC7550	Portable Alignment System	13
19968	Trailer Centering Gauge	21	404180	Saddle	43	LC7580	Computer Laser Wheel Alignment System - 4 Head	13
21130	Portable Rear Axle Aligner Cart	20	404	Tool Group 404	39	PLC750W	Laptop Rear Axle Alignment System	21
21320	Web Feelers - 4-inch	21	405BL	Tool Group 405BL	40	TLC750W	Cabinet Rear Axle Alignment System	21
21321	Web Feelers - 8-inch	21	406HDL	Tool Group 406HDL	41			
22000	Portable Rear Axle Aligner	25	406L	Tool Group 406L	41			
2300	Toe-In Gauge	14	406U	Tool Group 406U	42			
29070	Step - Runway Service	35	407CU	Tool Group 407CU	43			
29090	Step - Turning Aligner Service	35	407H	Tool Group 407HU	43			
29541	King Pin Turning Aligners (pair)	27, 29, 31	407U	Tool Group 407U - Upgrade Kit	42			
29540P	Portable Turning Aligners	33	4088	Smart Balancer II	50			
29544	Toe Gauge Support	35	6	Tool Group 6	44			
29600	Runway Lift Assembly	35						
3107A	Retroreflective Tape Rolls for Smart Balancer	50						
4000	Tire Truer	51						
4010	Tire Runout Gauge	52						

Index by Name

Part #	Description	Page #	Part #	Description	Page #	Part #	Description	Page #
109000	10 Ton Ram Extension Kit	47				AR400	Space Saver Ramp - 24" Runway Section	28, 29
403200	20 Ton Ram Extension Kit	47	782	Hose Quick Disconnect	34	AR400.30	Space Saver Ramp - 30" Runway Section	28
620013	7 Hex Nuts - 1 1/4-inch	40, 41, 43	1638A	Housing Cradle	44		Spacer	41
609024	7x6-inch Cap Screws - 1 1/4-inch	40, 41, 43	1670	Housing Cradle Adaptor	44	403098	Spacer	40, 41, 43
100AL	Aluminum Ram - 100 Ton	40	404102	Jack Base	39	404005	Spacer	40, 41, 43
100AL	Aluminum Ram - 100 Ton	41, 43	1588	Jack Base, Plate	40, 41	404120	Spacer	39
125AL	Aluminum Ram - 125 Ton	41, 43	1638	Jack Pad Weld - 4 1/4-inch high	40, 41, 44	404167	Spacer - Middle Ram to Axle	43
404168	Aluminum Ram Spacer Head 100T	42, 43	1639	Jack Stand - 7-inch	44	404166S	Spacer - Ram to Axle	43
404168A	Aluminum Ram Spacer Head 125T	42, 43	1585	Jack Tops	40, 41	404165	Spacer Beam to Conn - 1/2-inch	43
402600TA	Aluminum Runway	23	EPM718	King Pin Gauge	51	404165A	Spacer Beam to Conn - 1/4-inch	43
402620	Aluminum Storage Cart	33	29541	King Pin Turning Aligners (pair)	27, 29, 31	19356	Spindle Gauges - Car	17
404000	Axle Camber Beam - 56-inch Weld	40, 41, 43	PLC750W	Laptop Rear Axle Alignment System	21	19358	Spindle Gauges - Truck	17
404010A	Axle Clevis	40	LC7500	Laser Guided Computer Wheel Alignment System	10	404064	Spring Clevis Pad	41, 42
404163	Axle Connector	43	18410A	Manual Tram Gauge	20	15000.15	Spring Lift	40, 41, 43
800.1	Axle Support - 10 inch	34	404063	Narrow Clevis	41, 42	15000	Spring Lift with Chain	16
1230	Axle Support - 4-inch (optional)	34	404105	Narrow Clevis	39	404011A	Spring Pad Clevis	40
1225B	Axle Support - 6 5/8-inch	34	404119	Pin Adaptor Plate	39	404110	Spring Pad Clevis	39
800.2	Axle Support - Fabricated	34	404067	Pin Assembly - 1 1/2-inch diameter x 6-inch	39	403706	Stackable Fab Axle Push Block Stand	29, 45
1590	Axle Twisting Yokes	40, 41, 43	403003	Pin, Long - 1 1/4-inch x 8 1/2-inch	40, 41	899	Step - Removable Leg	35
404100SP	Beam	39	LC7550	Portable Alignment System	13	18546	Step - Runway Service	35
1650	Beam - 84-inch	44	402601	Portable Aluminum Ramp	23, 33	29070	Step - Turning Aligner Service	35
404100AL	Beam - Aluminum	39	402600TA	Portable Aluminum Runway Section	23, 33	29090	Supply Hose - 15 ft.	34
15150A	Beam Lift Assembly Omega Jack	41, 43	402600	Portable Aluminum Runway Section - w/ cut-out	23, 33	780	Support End Leg - 24-inch	27
1630	Beam Support	44	LC7060	Portable Case	17, 23	176	Tire Runout Gauge	52
1589	Block	40, 41, 43	22000	Portable Rear Axle Aligner	25	4010	Tire Scribe Gauge	14
1510A	Block, Spacer - 3/8-inch x 1 3/4-inch x 5-inch	40, 41, 43	21130	Portable Rear Axle Aligner Cart	20	1790	Tire Truer	51
1512A	Block, Spacer - 1-inch x 1 3/4-inch x 5-inch	40, 41, 43	29540P	Portable Turning Aligners	33	4000	Toe Gauge Support	35
404170C	Boot	42, 43	FPT8000	Portable Turn Plate - Aluminum	15	2300	Toe-In Gauge	14
TLC750W	Cabinet Rear Axle Alignment System	21	FPT9500	Portable Turn Plate - Heavy Duty	15	404	Tool Group 404	39
1624	Cable Slings	44	FPT8500	Portable Turn Plate - Steel	15, 23, 25	405BL	Tool Group 405BL	40
1614	Cables	44	875	PSI Gauge - Standard	45	406HDL	Tool Group 406HDL	41
18334	Calibration Bar - Mechanical Gauges	14	900E	Pump, 2 Valve - Alignment Applications	45	406L	Tool Group 406L	41
404151	Caster Correcting Yoke (optional)	39	900D	Pump, 2 Valve - Solenoid Operated Valve	45	406U	Tool Group 406U	42
18305	Caster-Camber Gauge - Cars	14	900B	Pump, 4 Valve - Frame Applications	45	407CU	Tool Group 407CU	43
19305	Caster-Camber Gauge - Trucks	14	900C	Pump, 4 Valve - Solenoid Operated Valve	45	407H	Tool Group 407HU	43
15015	Chain - 5/16-inch	40, 41, 43	7500	Pump, Foot or Hand Operated, 2 Gallon Reservoir	45	407U	Tool Group 407U - Upgrade Kit	42
404150	Clevis - Medium Duty (optional)	39	403705	Push Block - 60 Ton	43	6	Tool Group 6	44
404016	Clevis Pins	40	FR10	Ram - 10 Ton, 6 1/8-inch Stroke	40, 41, 43, 46	19968	Trailer Centering Gauge	21
LC7580	Computer Laser Wheel Alignment System - 4 Head	13	FR30	Ram - 30 Ton	39	7710	Trailer Extensions for Floor Jack (pair)	17
404075	Confined Area Clevis	42	1675	Ram Holder	44	100AL.3B	Transport Ring - 100 Ton	40, 41, 43
404055	Connecting Link Weld (new style)	41, 43	FR10.16	Ram, Long with HD Couplers - 10 Ton	46	125AL.3B	Transport Ring - 125 Ton	41, 43
404116	Connector	39	FR20.19	Ram, Long with HD Couplers - 20 Ton	46	EPM715	Tread Depth Gauge	16
404060	Connector SD Weld	41, 42	FR10.5	Ram, Short with HD Couplers - 10 Ton	46	404052A	Twisting Hook	40
404012	Connector Weld	40	FR20	Ram, Standard with HD Couplers - 20 Ton	46	1416	Twisting Hook for Caster Correction (optional)	39
19290	Dolly Aligner Target	21	FPT7860	Rear Slip Plates	15	21320	Web Feelers - 4"	21
AR330D	Double Approach Ramps - 24-inch	27	404052A	Rear Twisting Hook	40, 41, 43	21321	Web Feelers - 8"	21
900	Electric Hydraulic Pump	29, 45	EPM720	Remote Display	17, 25	LC4101.1	Wheel Mount - Cam Advancer	15
EPM940	Electronic Target	20	3107A	Retroreflective Tape Rolls for Smart Balancer	50	LC4195B.1	Wheel Mount - Center Mount	16
18410E	Electronic Tram Gauge	20	826.12S	Riser 6"	34	LC4102.1	Wheel Mount - Self-Centering	16
744.15	Extended Beam 64"	34	174	Runway Legs - 24-inch	27, 31	EPE261W	Wireless Wall Charging Station	17
404055	Extension	40	175	Runway Legs - 30-inch	31	404067	Yoke Clevis Pin Weld - 6"	41, 42
1225EXT	Extension Assembly - 3-inch (optional)	34	29600	Runway Lift Assembly	35	404065	Yoke Clevis Pin Weld - 8"	41, 42, 43
1607	Extensions	44	404180	Saddle	43			
1225EXT	Extensions - 3 inch	34	804.175	Safety Stands - 7 1/2 inch	34			
814.1	Extra Long Axle Support - 14 1/4-inch (optional)	34	19020A	Seat Gauge - Digital Spring	16			
FJ7700	Floor Jack	17, 23, 25, 51	19020	Seat Gauge - Spring	16			
404030	Front Twisting Hook	40, 41, 43	1122	Short Pins	44			
885.12D	Heavy Duty Dual Air Jack - 24-inch	27, 31, 34	4088	Smart Balancer II	50			
878.12D	Heavy Duty Dual Air Jack - 30-inch	34						
404170PP	High Capacity Axle Strap - 36"	42, 43						
404170.40PP	High Capacity Axle Strap - 40"	42, 43						



A **McLAUGHLIN** Company

For Parts, Service, Training or Technical Questions, Visit Us Online at
beeline-co.com or Call Toll Free **800-728-7828**

2700 62nd Street Court • Bettendorf, Iowa 52722 • Fax 563-332-6517